

Luci SHIN UQ FLEX / Luci SHIN UQ FLEX α

LFUY-I / LFUAY-I **SHIN** series **NEW**



TOKYO MIDTOWN HIBIYA
Location: Japan
Architect office: NOMURA Co., Ltd.

Lighting Design: Noosa Design Co., Ltd.
Construction: KAJIMA CORPORATION
Photo: Nacása & Partners Inc.



JG Dubai
Location: Dubai
Architects Office: Curiosity

Lighting Design: L'Observatoire International
Construction: RK Gulf LLC
Photo: Nacása & Partners Inc.

Luci SHIN UQ FLEX Indoor / Luci SHIN UQ FLEX α Indoor

Available 4 different wattage variations
 Indoor usage only, custom length max.5m per roll, connectable 5m per circuit
 LFUY: Verical (Top) bend
 LFUAY: Horizontal (Side) bend

Indoor

Strip Light

LFUY-I / LFUAY-I SHIN UQ FLEX Indoor / SHIN UQ FLEX α Indoor

Specifications

Dimensions

Cross section W 18.3 x H 17.3 mm
 Custom order up to 5m at every 50 mm length with both ends or one end feed cable
 Up to 5 m in 50 mm increment

Feed cables are available in two directions: side or back feed

Cuttable the light fixture every 50mm at site. If a luminaire with a both-side feed cable is cut, the left and right sides of the luminaire can be used separately, as if the luminaire were a one-side feed.

Electrical & Output @2700K

LFU-I			SHIN series LFUY-I			Efficacy Improvement
W/m	lm/m	lm/W	W/m	lm/m	lm/W	
8.4 W/m	415 lm/m	49 lm/W	6.4 W/m	629 lm/m	98.5 lm/W	199%
12.6 W/m	623 lm/m	49 lm/W	10.8 W/m	1047 lm/m	96.6 lm/W	196%
15.8 W/m	781 lm/m	49 lm/W	15.9 W/m	1538 lm/m	96.8 lm/W	196%
			20.7 W/m	1936 lm/m	93.7 lm/W	

LFUA-I			SHIN series LFUAY-I			Efficacy Improvement
W/m	lm/m	lm/W	W/m	lm/m	lm/W	
8.4 W/m	289 lm/m	34 lm/W	6.4 W/m	477 lm/m	74.6 lm/W	217%
12.6 W/m	448 lm/m	36 lm/W	10.8 W/m	794 lm/m	73.3 lm/W	207%
15.8 W/m	561 lm/m	36 lm/W	15.9 W/m	1198 lm/m	75.4 lm/W	212%
			20.7 W/m	1460 lm/m	70.6 lm/W	

Color temperature



Ra > 90

Please refer to the product specification page for the delivered CCT.

Optics

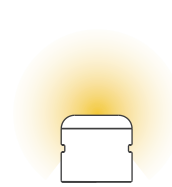

- Unique rounded corner light emitting surface for wide light distribution for less unpleasant peaks on the illuminated surface

- Cross-sectional size common to LFUY-I and LFUAY-I

Min Bending radius



Features

Cable feed directions

Back feed

For cove/recessed light in various cable outgoing directions



Side(Right) feed

For indirect cove

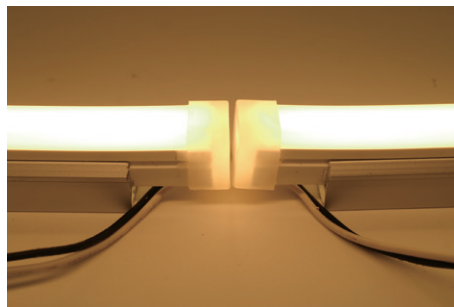

Less visible dark spot at joint
 Easy and safe connection of two fixtures with attached connector

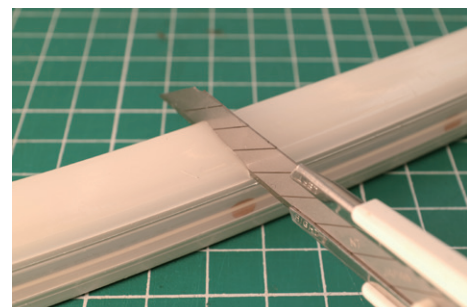

Customise and cuttable at site every 50mm length
 Suitable for complex length projects which can't expect accurate length when ordering

Up to 5m of luminaire per run. Less concern of PSU location!

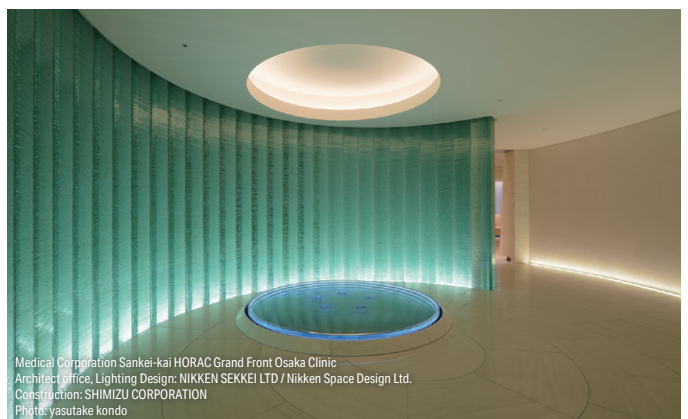
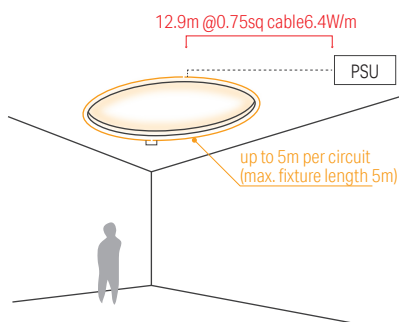

LFUY-I SHIN series NEW



- Top bend dot-free flexible light, cuttable every 50mm at site
- Updated with low wattage high lumen LED series
- Available 4 different wattage variations
- Indoor usage only, custom length max.5m per roll, connectable 5m per circuit

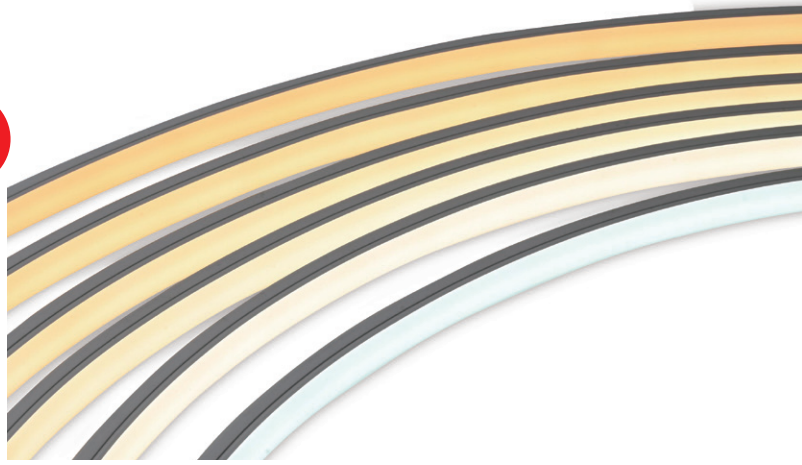

Model No.

LFUY		-	T	<input type="checkbox"/>	<input type="checkbox"/>	-	<input type="checkbox"/>	-	DF	-	I	-	<input type="checkbox"/>
Product Name	Length	Lead wire	Lead wire	Light source color		Tube type	Environment	Wattage					
LFUY	Custom order length	W : Both ends S : One ends	B : Back feed R : Side(Right) feed	D : 6500K N : 5000K W : 4000K WW : 3500K	L30 : 3000K L27 : 2700K L25 : 2500K L22 : 2200K L20 : 2000K	DF : Diffuser	I : Indoor	6 : 6.4 W/m 10 : 10.8 W/m 15 : 15.9 W/m 20 : 20.7 W/m					

Specification

Model No.	LFUY-T1000S/WB/R-DF-I-6	LFUY-T1000S/WB/R-DF-I-10	LFUY-T1000S/WB/R-DF-I-15	LFUY-T1000S/WB/R-DF-I-20
Wattage	6.4 W/m	10.8 W/m	15.9 W/m	20.7 W/m
Fitting length	1008 mm (Refer to Custom order length)			
Weight	-			
Luminaire efficacy(2700K)	98.5 lm/W	96.6 lm/W	96.8 lm/W	93.7 lm/W
Light source color	○ = Device inventory * = Please contact us since it's built to order			
D 6500K	Ra96 * 711 lm	* 1183 lm	* 1738 lm	* 2188 lm
N 5000K	Ra93 ○ 705 lm	○ 1172 lm	○ 1722 lm	○ 2169 lm
W 4000K	Ra97 ○ 692 lm	○ 1151 lm	○ 1691 lm	○ 2130 lm
WW 3500K	Ra97 ○ 686 lm	○ 1141 lm	○ 1676 lm	○ 2111 lm
L30 3000K	Ra95 ○ 667 lm	○ 1110 lm	○ 1630 lm	○ 2053 lm
L27 2700K	Ra94 ○ 629 lm	○ 1047 lm	○ 1538 lm	○ 1936 lm
L25 2500K	Ra94 ○ 466 lm	○ 775 lm	○ 1138 lm	○ 1433 lm
L22 2200K	Ra93 * 434 lm	* 722 lm	* 1061 lm	* 1336 lm
L20 2000K	Ra91 * 397 lm	* 659 lm	* 969 lm	* 1220 lm

Please contact our sales staff regarding the delivered CCT.

The optical data provided on the each product pages are for reference only; the data values are not guaranteed. Please use as reference materials for your planning.

General Specification

Input voltage	DC24V
Environment	Indoors (no condensation)
Max. fixture length	5m
Max. length Per circuit	5m
Min. bending range	R150mm
Material	Silicone
Attachments	④ End cap 2pcs
Accessories	① Mounting rail set ② Mounting parts set ③ Mounting Clip ④ End cap ⑤ Power supply cable ⑥ Joint cable
Certification	CE
Dimmable	Yes (0-10V/1-10V, DMX, DALI, PWM, Casambi)

Max. connectable length per PSU

Length of light fixture (70% loading factor) *: split into multiple circuits				PSU
6.4 W/m	10.8 W/m	15.9 W/m	20.7 W/m	50W
~5.5 m*	~3.2 m	~2.2 m	~1.7 m	
~11 m*	~6.5 m*	~4.4 m	~3.4 m	
~16.4 m*	~9.7 m*	~6.6 m*	~5.1 m*	150W

External dimensions

W: Both ends lead, B: Back feed

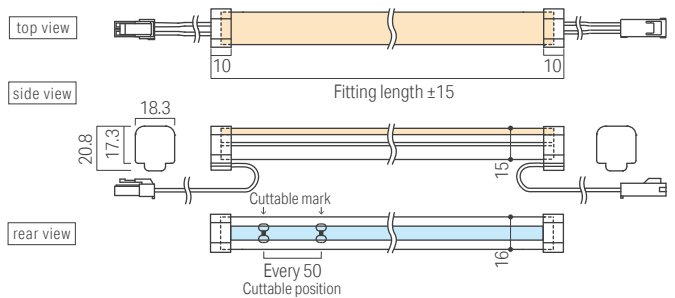

W: Both ends lead, R: Side(Right) feed

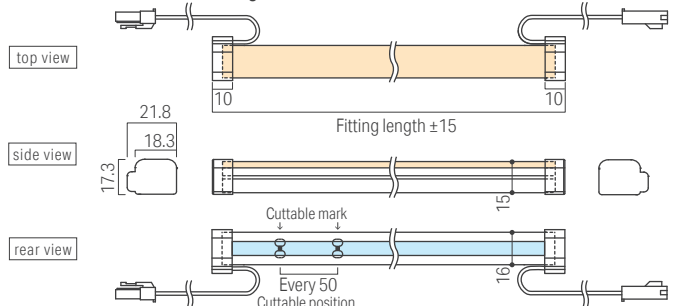

Cross sectional view with accessories

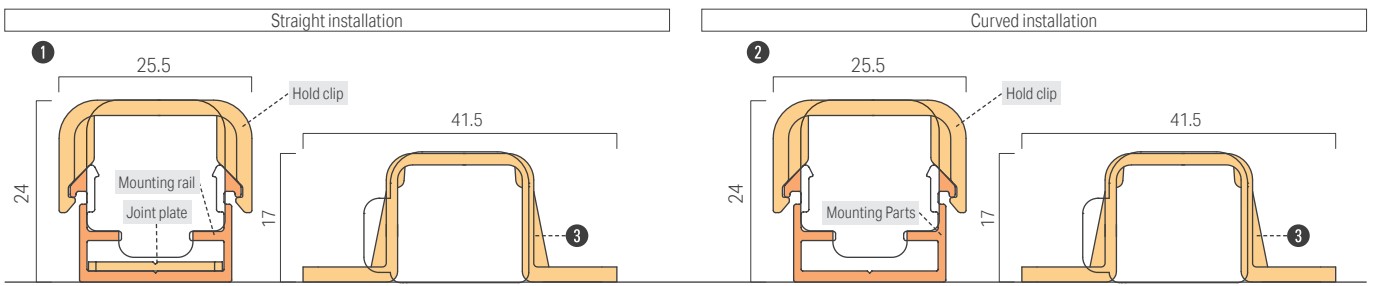

Accessories

1 Aluminium mounting rail 950 set for UQ FLEX Indoor
 Model No : LFU-RL0950-AL-C-1
 The set includes Mounting rail (1pc) and PC Hold clip (5 pcs/bag) and Joint plate (1pc)
 For straight installation (Back/Side feed)

6 Joint cable 1000mm / 5000mm for SL connector
 Model No : CAD-1000-MCFC-I / CAD-5000-MCFC-I

Custom order Length

Luci SHIN UQ FLEX Indoor (6.4 W/m, 10.8 W/m, 15.8 W/m, 20.7 W/m)
 Corresponds to Length of Model No. and External dimensions

Length	Fitting length (mm)			Length	Fitting length (mm)		
	WR/WB	SR	SB		WR/WB	SR	SB
0050	58	57.5	57	2550	2558	2557.5	2557
0100	108	107.5	107	2600	2608	2607.5	2607
0150	158	157.5	157	2650	2658	2657.5	2657
0200	208	207.5	207	2700	2708	2707.5	2707
0250	258	257.5	257	2750	2758	2757.5	2757
0300	308	307.5	307	2800	2808	2807.5	2807
0350	358	357.5	357	2850	2858	2857.5	2857
0400	408	407.5	407	2900	2908	2907.5	2907
0450	458	457.5	457	2950	2958	2957.5	2957
0500	508	507.5	507	3000	3008	3007.5	3007
0550	558	557.5	557	3050	3058	3057.5	3057
0600	608	607.5	607	3100	3108	3107.5	3107
0650	658	657.5	657	3150	3158	3157.5	3157
0700	708	707.5	707	3200	3208	3207.5	3207
0750	758	757.5	757	3250	3258	3257.5	3257
0800	808	807.5	807	3300	3308	3307.5	3307
0850	858	857.5	857	3350	3358	3357.5	3357
0900	908	907.5	907	3400	3408	3407.5	3407
0950	958	957.5	957	3450	3458	3457.5	3457
1000	1008	1007.5	1007	3500	3508	3507.5	3507
1050	1058	1057.5	1057	3550	3558	3557.5	3557
1100	1108	1107.5	1107	3600	3608	3607.5	3607
1150	1158	1157.5	1157	3650	3658	3657.5	3657
1200	1208	1207.5	1207	3700	3708	3707.5	3707
1250	1258	1257.5	1257	3750	3758	3757.5	3757
1300	1308	1307.5	1307	3800	3808	3807.5	3807
1350	1358	1357.5	1357	3850	3858	3857.5	3857
1400	1408	1407.5	1407	3900	3908	3907.5	3907
1450	1458	1457.5	1457	3950	3958	3957.5	3957
1500	1508	1507.5	1507	4000	4008	4007.5	4007
1550	1558	1557.5	1557	4050	4058	4057.5	4057
1600	1608	1607.5	1607	4100	4108	4107.5	4107
1650	1658	1657.5	1657	4150	4158	4157.5	4157
1700	1708	1707.5	1707	4200	4208	4207.5	4207
1750	1758	1757.5	1757	4250	4258	4257.5	4257
1800	1808	1807.5	1807	4300	4308	4307.5	4307
1850	1858	1857.5	1857	4350	4358	4357.5	4357
1900	1908	1907.5	1907	4400	4408	4407.5	4407
1950	1958	1957.5	1957	4450	4458	4457.5	4457
2000	2008	2007.5	2007	4500	4508	4507.5	4507
2050	2058	2057.5	2057	4550	4558	4557.5	4557
2100	2108	2107.5	2107	4600	4608	4607.5	4607
2150	2158	2157.5	2157	4650	4658	4657.5	4657
2200	2208	2207.5	2207	4700	4708	4707.5	4707
2250	2258	2257.5	2257	4750	4758	4757.5	4757
2300	2308	2307.5	2307	4800	4808	4807.5	4807
2350	2358	2357.5	2357	4850	4858	4857.5	4857
2400	2408	2407.5	2407	4900	4908	4907.5	4907
2450	2458	2457.5	2457	4950	4958	4957.5	4957
2500	2508	2507.5	2507	5000	5008	5007.5	5007

2 AL mounting parts set for UQ FLEX Indoor
 Model No : LFU-RL0018-AL-C-1
 The set include Mounting parts (5 pcs/bag) and PC Hold clip (5 pcs/bag)
 Recommended each 5 pcs/m
 For curved installation (Back/Side feed)

3 PC Mounting clip for UQ FLEX
 Model No : LFU-RC
 5 pcs/bag
 Recommended 5 pcs/m
 For curved installation (Side feed)
 *When back feed, need a hole for endcap on installation surface.

4 Endcap for UQ FLEX indoor
 Model No : LFU-EC
 Attached with light fixture (2pcs/bag) for extra order 2pcs/bag

5 Power supply cable 3000mm for SL connector **Required**
 Model No : CAD-3000-MCINN-I

Cross sectional view with accessories

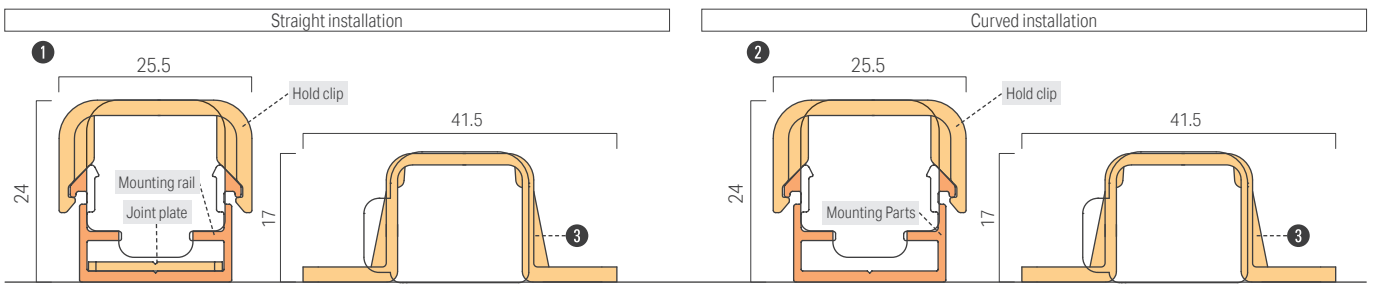

Accessories

1 Aluminium mounting rail 950 set for UQ FLEX Indoor
 Model No : LFU-RL0950-AL-C-1
 The set includes Mounting rail (1pc) and PC Hold clip (5 pcs/bag) and Joint plate (1pc)
 For straight installation (Back/Side feed)

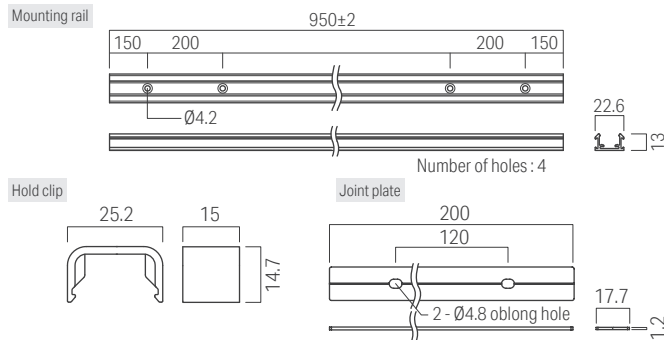

6 Joint cable 1000mm / 5000mm for SL connector
 Model No : CAD-1000-MCFC-I / CAD-5000-MCFC-I



Custom order length

Luci SHIN UQ FLEX α Indoor (6.4 W/m, 10.8 W/m, 15.8 W/m, 20.7 W/m)
 Corresponds to Length of Model No. and External dimensions

Length	Fitting length (mm)			Length	Fitting length (mm)		
	WR/WB	SR	SB		WR/WB	SR	SB
0050	58	57.5	57	2550	2558	2557.5	2557
0100	108	107.5	107	2600	2608	2607.5	2607
0150	158	157.5	157	2650	2658	2657.5	2657
0200	208	207.5	207	2700	2708	2707.5	2707
0250	258	257.5	257	2750	2758	2757.5	2757
0300	308	307.5	307	2800	2808	2807.5	2807
0350	358	357.5	357	2850	2858	2857.5	2857
0400	408	407.5	407	2900	2908	2907.5	2907
0450	458	457.5	457	2950	2958	2957.5	2957
0500	508	507.5	507	3000	3008	3007.5	3007
0550	558	557.5	557	3050	3058	3057.5	3057
0600	608	607.5	607	3100	3108	3107.5	3107
0650	658	657.5	657	3150	3158	3157.5	3157
0700	708	707.5	707	3200	3208	3207.5	3207
0750	758	757.5	757	3250	3258	3257.5	3257
0800	808	807.5	807	3300	3308	3307.5	3307
0850	858	857.5	857	3350	3358	3357.5	3357
0900	908	907.5	907	3400	3408	3407.5	3407
0950	958	957.5	957	3450	3458	3457.5	3457
1000	1008	1007.5	1007	3500	3508	3507.5	3507
1050	1058	1057.5	1057	3550	3558	3557.5	3557
1100	1108	1107.5	1107	3600	3608	3607.5	3607
1150	1158	1157.5	1157	3650	3658	3657.5	3657
1200	1208	1207.5	1207	3700	3708	3707.5	3707
1250	1258	1257.5	1257	3750	3758	3757.5	3757
1300	1308	1307.5	1307	3800	3808	3807.5	3807
1350	1358	1357.5	1357	3850	3858	3857.5	3857
1400	1408	1407.5	1407	3900	3908	3907.5	3907
1450	1458	1457.5	1457	3950	3958	3957.5	3957
1500	1508	1507.5	1507	4000	4008	4007.5	4007
1550	1558	1557.5	1557	4050	4058	4057.5	4057
1600	1608	1607.5	1607	4100	4108	4107.5	4107
1650	1658	1657.5	1657	4150	4158	4157.5	4157
1700	1708	1707.5	1707	4200	4208	4207.5	4207
1750	1758	1757.5	1757	4250	4258	4257.5	4257
1800	1808	1807.5	1807	4300	4308	4307.5	4307
1850	1858	1857.5	1857	4350	4358	4357.5	4357
1900	1908	1907.5	1907	4400	4408	4407.5	4407
1950	1958	1957.5	1957	4450	4458	4457.5	4457
2000	2008	2007.5	2007	4500	4508	4507.5	4507
2050	2058	2057.5	2057	4550	4558	4557.5	4557
2100	2108	2107.5	2107	4600	4608	4607.5	4607
2150	2158	2157.5	2157	4650	4658	4657.5	4657
2200	2208	2207.5	2207	4700	4708	4707.5	4707
2250	2258	2257.5	2257	4750	4758	4757.5	4757
2300	2308	2307.5	2307	4800	4808	4807.5	4807
2350	2358	2357.5	2357	4850	4858	4857.5	4857
2400	2408	2407.5	2407	4900	4908	4907.5	4907
2450	2458	2457.5	2457	4950	4958	4957.5	4957
2500	2508	2507.5	2507	5000	5008	5007.5	5007

2 AL mounting parts set for UQ FLEX Indoor
 Model No : LFU-RL0018-AL-C-1
 The set include Mounting parts (5 pcs/bag) and PC Hold clip (5 pcs/bag)
 Recommended each 5 pcs/m
 For curved installation (Back/Side feed)

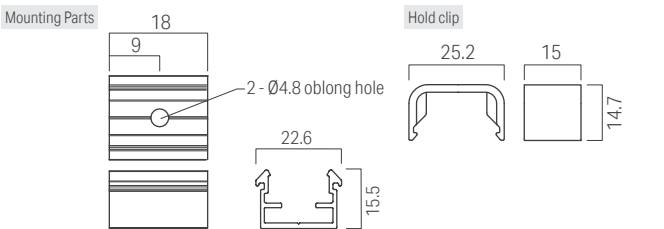

3 PC Mounting clip for UQ FLEX
 Model No : LFU-RC
 5 pcs/bag
 Recommended 5 pcs/m
 For curved installation (Side feed)
 *When back feed, need a hole for endcap on installation surface.

4 Endcap for UQ FLEX indoor
 Model No : LFU-EC
 Attached with light fixture (2pcs/bag) for extra order 2pcs/bag

5 Power supply cable 3000mm for SL connector **Required**
 Model No : CAD-3000-MCINN-I

Installing the product

Installation with Mounting rail

1 Aluminium mounting rail 950 set for UQ FLEX Indoor (LFU-RL0950-AL-C-I)

- ① Fix the aluminium rail by screws (pan head screw M4 recommended) supplied by installer. The screw holes at both ends should be left unused for installing with the Joint plate.

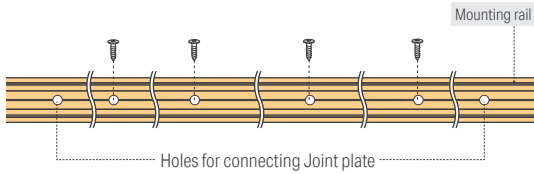

- ② When two or more rails are installed in a straight line, insert the Joint plate into bottom of the rail.

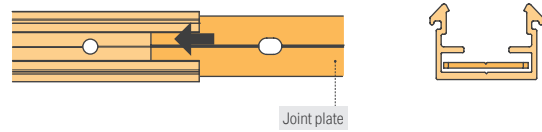

- ③ Put the second rail and slide the Joint plate as below.

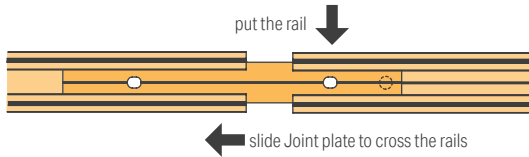

- ④ Fix the holes of rails and plate altogether by screws.

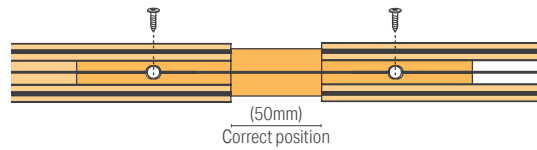

- ⑤ Fix the holes of second rail for installation like ①...

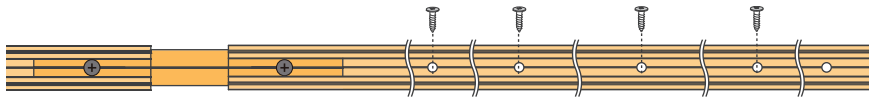

LFUY-I Top / Vertical bend only

- ⑥ Hold one side of the light fixture and gradually push on the other side into the aluminum rail.

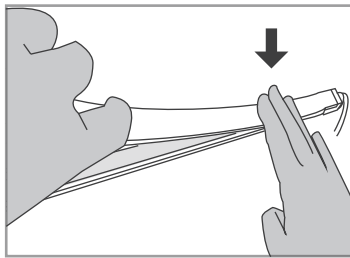

LFUAY-I Side / Horizontal bend only

- ⑥ When installing LFUAY (side bend) on the mounting rail, the light fixture shall first be placed horizontally on the rail and the entire light fixture shall be pushed gradually horizontally into the rail so that the light fixture does not bend vertically.

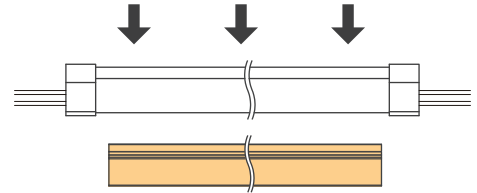

- ⑦ Push the PC hold clip for UQ FLEX rail (LFU-PT-B) until click sound and make sure it is securely locked. SUS hold clip is recommended in the environment where requires durability or downwards installation. Recommended number of LFU-PT-B is minimum 3 pcs/m.

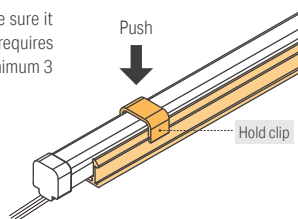

Installation with Mounting clip

3 PC Mounting clip for UQ FLEX (LFU-RC)

- ① Place the light fixture on the surface to be installed. Do not twist and bend the light fixture in the wrong direction.
- ② Fix the mounting clip by 2pcs of screws supplied by installer.(pan head screw M4 recommended) The recommended distance between clips is 200 mm or less. The clips at both ends should be 50 mm away from the ends of the LED luminaire to prevent it from lifting.

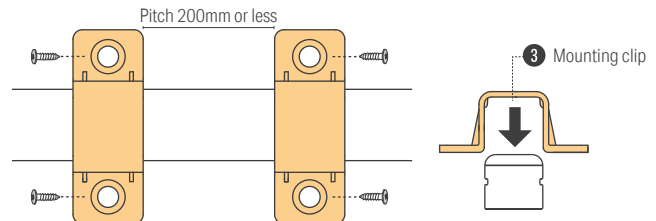

Installation with Mounting parts

2 AL mounting parts set for UQ FLEX Indoor (LFU-RL0018-AL-C-I)

- ① Fix the aluminum mounting parts by 1 pc of screw to the points where the light fixture is to be installed. (pan head screw M4 recommended) The recommended distance between clips is 200 mm or less. The mounting parts at both ends should be 50 mm away from the ends of the light fixture to prevent it from lifting.
- ② Push the light fixture into the clip while keeping the correct bending direction. Caution: Do not bend the light fixture in the wrong direction.
- ③ Put the PC hold clip (LFU-PT-B) until click sound and make sure it is securely locked. The hold clips should be used if the light fixture is easily dislodged or installed downward.

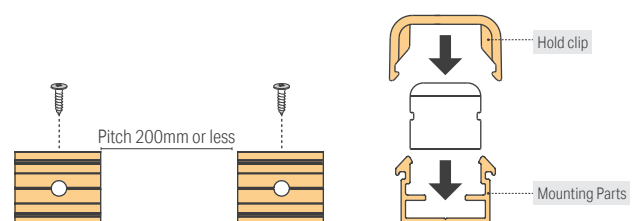

Cutting and terminal sealing

LFUY-I Top / Vertical bend only

Pen knife/Box cutter
Push the blade straight down

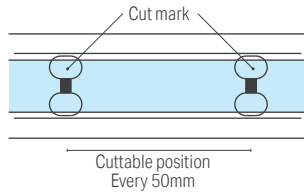
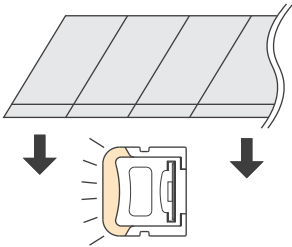

LFUAY-I Side / Horizontal bend only

Pen knife/Box cutter
Push the blade straight down

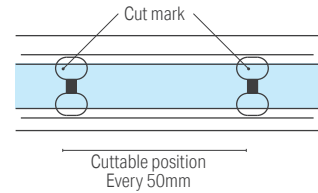
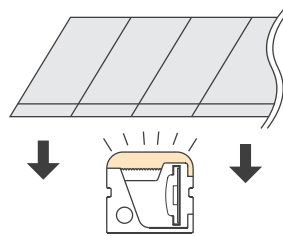

Wipe off any dirt, etc. from the adhesive area.

Use a thin blade such as a Pen knife/Box cutter for cutting. Use of thick blades, scissors, nippers, etc. will bend the board and cause malfunctions.

When cutting the light fixture, be sure to cut at the cutting marks shown above. If anywhere other than the cut mark is cut, the light fixture will not turn on. When cutting, push the blade straight down along the cutting mark. Pulling the blade back and forth like a saw may cause the circuit board to fold, resulting in malfunction.

Cutting should always be done on a flat, stable surface.

The cut and insulated light fixture with end cap can only be used indoors. Do not install the products in wet or humid places.

Before installation and lighting, check that the cap adheres properly.

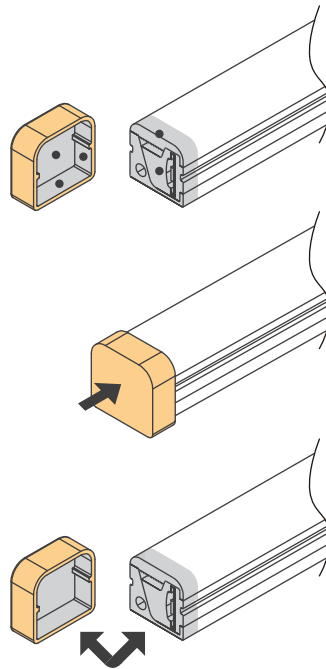

Apply primer on the cut area of the light fixture and the inside of the cap (gray area in the figure).

Apply sufficient adhesive on the cut area of the light fixture and the inside of the cap (gray area in the figure).

Immediately attach the end cap to the light fixture and dry it for at least 30 minutes.

System configuration diagram

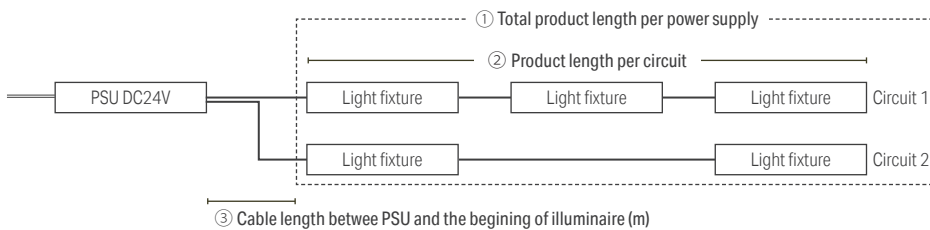

- Total product length per PSU depends on capacity of the PSU. Recommended loading factor is 70% (without dimming) or 60% (with dimming).
- Product length per circuit shall not exceed maximum product length per circuit. If the product length per circuit exceeds the maximum, split into multiple circuits.
- To minimize voltage drop, select appropriate wire gauge / diameter and consider the cable length between PSU and the beginning of luminaire referring to the following table. If longer cable distances are required, use thicker wires or reduce the loading of the light fixtures in the circuit.

① Max. connectable length per PSU

Length of light fixture (70% loading factor) *: split into multiple circuits				PSU
6.4 W/m	10.8 W/m	15.9 W/m	20.7 W/m	50W
~5.5 m*	~3.2 m	~2.2 m	~1.7 m	
~11 m*	~6.5 m*	~4.4 m	~3.4 m	
~16.4 m*	~9.7 m*	~6.6 m*	~5.1 m*	
				100W
				150W

Model No.	Wattage	Cross section		Wire gauze	
		0.3 sq	0.5 sq	AWG 22	AWG 20
				0.75 sq	
				AWG 18	
Model No.	Wattage	② Max length per circuit	③ Max cable length between PSU and the top of luminaire at ②	② Max length per circuit	
LFUY/LFUAY-T1000***-DF-I-6	6.4 W/m	5 m	5.1 m	8.2 m	12.9 m
LFUY/LFUAY-T1000***-DF-I-10	10.8 W/m	5 m	3.0 m	4.9 m	7.6 m
LFUY/LFUAY-T1000***-DF-I-15	15.9 W/m	5 m	2.0 m	3.3 m	5.2 m
LFUY/LFUAY-T1000***-DF-I-20	20.7 W/m	5 m	1.6m	2.6m	4.0m

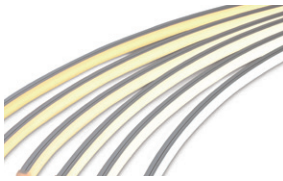

LFUY Luci SHIN UQ FLEX

Color temperature

6500K 5000K 4000K 3500K 3000K 2700K 2500K 2200K 2000K

Direct horizontal surface light intensity distribution chart - 6W

LFUY-T1000**-D-DF-I-6

Light source color 6500K
Brightness 196 cd
Luminous flux 711 lm
Color rendering index Ra 96

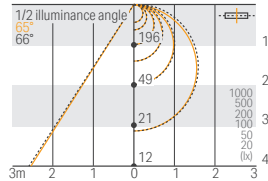

LFUY-T1000**-N-DF-I-6

Light source color 5000K
Brightness 191 cd
Luminous flux 705 lm
Color rendering index Ra 93

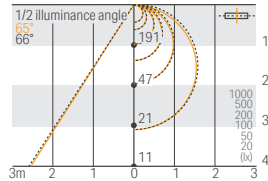

LFUY-T1000**-W-DF-I-6

Light source color 4000K
Brightness 188 cd
Luminous flux 692 lm
Color rendering index Ra 97

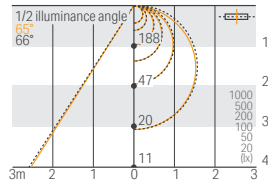

LFUY-T1000**-WW-DF-I-6

Light source color 3500K
Brightness 186 cd
Luminous flux 686 lm
Color rendering index Ra 97

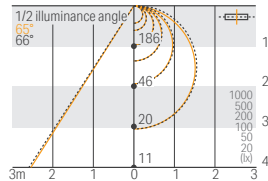

LFUY-T1000**-L30-DF-I-6

Light source color 3000K
Brightness 181 cd
Luminous flux 667 lm
Color rendering index Ra 95

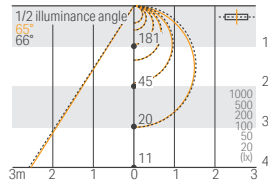

LFUY-T1000**-L27-DF-I-6

Light source color 2700K
Brightness 171 cd
Luminous flux 629 lm
Color rendering index Ra 94

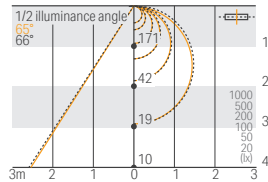

LFUY-T1000**-L25-DF-I-6

Light source color 2500K
Brightness 126 cd
Luminous flux 466 lm
Color rendering index Ra 94

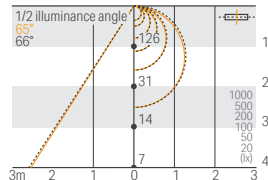

LFUY-T1000**-L22-DF-I-6

Light source color 2200K
Brightness 118 cd
Luminous flux 434 lm
Color rendering index Ra 93

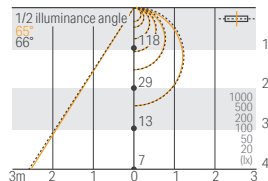

LFUY-T1000**-L20-DF-I-6

Light source color 2000K
Brightness 107 cd
Luminous flux 397 lm
Color rendering index Ra 91

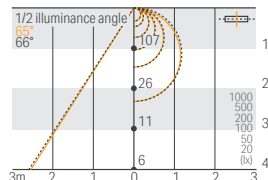

Direct horizontal surface light intensity distribution chart - 10W

LFUY-T1000**-D-DF-I-10

Light source color 6500K
Brightness 307 cd
Luminous flux 1183 lm
Color rendering index Ra 96

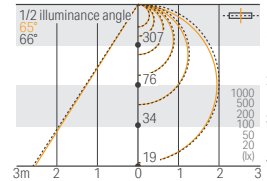

LFUY-T1000**-N-DF-I-10

Light source color 5000K
Brightness 299 cd
Luminous flux 1172 lm
Color rendering index Ra 93

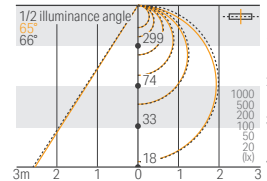

LFUY-T1000**-W-DF-I-10

Light source color 4000K
Brightness 294 cd
Luminous flux 1151 lm
Color rendering index Ra 97

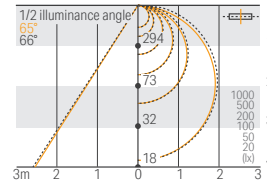

LFUY-T1000**-WW-DF-I-10

Light source color 3500K
Brightness 291 cd
Luminous flux 1141 lm
Color rendering index Ra 97

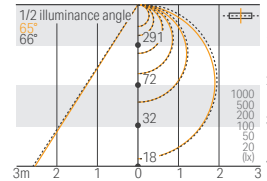

LFUY-T1000**-L30-DF-I-10

Light source color 3000K
Brightness 283 cd
Luminous flux 1110 lm
Color rendering index Ra 95

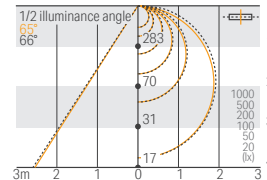

LFUY-T1000**-L27-DF-I-10

Light source color 2700K
Brightness 267 cd
Luminous flux 1047 lm
Color rendering index Ra 94

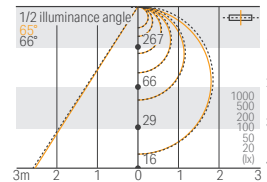

LFUY-T1000**-L25-DF-I-10

Light source color 2500K
Brightness 197 cd
Luminous flux 775 lm
Color rendering index Ra 94

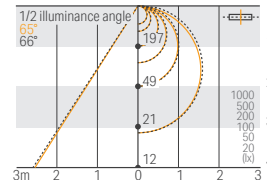

LFUY-T1000**-L22-DF-I-10

Light source color 2200K
Brightness 184 cd
Luminous flux 722 lm
Color rendering index Ra 93

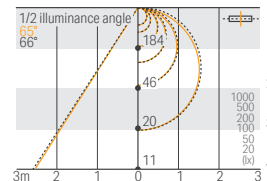

LFUY-T1000**-L20-DF-I-10

Light source color 2000K
Brightness 168 cd
Luminous flux 659 lm
Color rendering index Ra 91

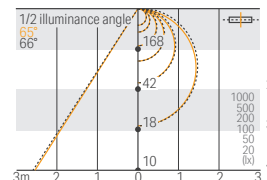

Illuminance data



LFUY Luci SHIN UQ FLEX

Color temperature

6500K 5000K 4000K 3500K 3000K 2700K 2500K 2200K 2000K

Direct horizontal surface light intensity distribution chart - 15W

LFUY-T1000**D-DF-I-15
Light source color 6500K
Brightness 437 cd
Luminous flux 1738 lm
Color rendering index Ra 96

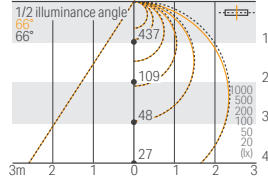

LFUY-T1000**N-DF-I-15
Light source color 5000K
Brightness 425 cd
Luminous flux 1722 lm
Color rendering index Ra 93

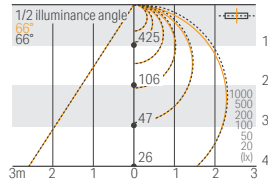

LFUY-T1000**W-DF-I-15
Light source color 4000K
Brightness 418 cd
Luminous flux 1691 lm
Color rendering index Ra 97

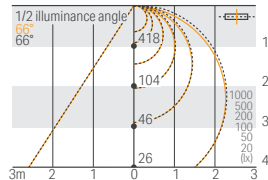

LFUY-T1000**WW-DF-I-15
Light source color 3500K
Brightness 414 cd
Luminous flux 1676 lm
Color rendering index Ra 97

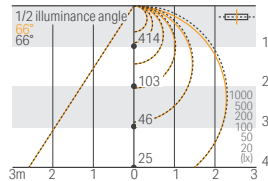

LFUY-T1000**L30-DF-I-15
Light source color 3000K
Brightness 402 cd
Luminous flux 1630 lm
Color rendering index Ra 95

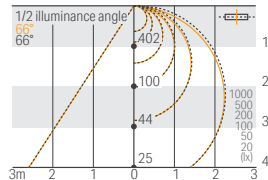

LFUY-T1000**L27-DF-I-15
Light source color 2700K
Brightness 380 cd
Luminous flux 1538 lm
Color rendering index Ra 94

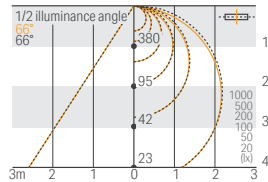

LFUY-T1000**L25-DF-I-15
Light source color 2500K
Brightness 281 cd
Luminous flux 1138 lm
Color rendering index Ra 94

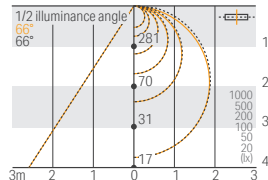

LFUY-T1000**L22-DF-I-15
Light source color 2200K
Brightness 262 cd
Luminous flux 1061 lm
Color rendering index Ra 93

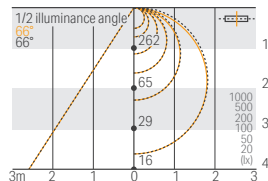

LFUY-T1000**L20-DF-I-15
Light source color 2000K
Brightness 239 cd
Luminous flux 969 lm
Color rendering index Ra 91

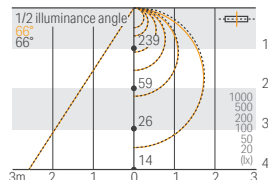

Direct horizontal surface light intensity distribution chart - 20W

LFUY-T1000**D-DF-I-20
Light source color 6500K
Brightness 581 cd
Luminous flux 2188 lm
Color rendering index Ra 96

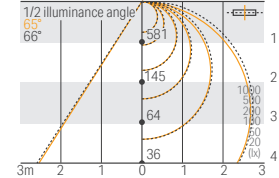

LFUY-T1000**N-DF-I-20
Light source color 5000K
Brightness 566 cd
Luminous flux 2169 lm
Color rendering index Ra 93

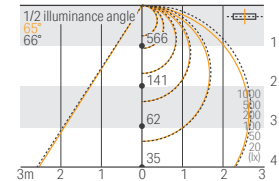

LFUY-T1000**W-DF-I-20
Light source color 4000K
Brightness 555 cd
Luminous flux 2130 lm
Color rendering index Ra 97

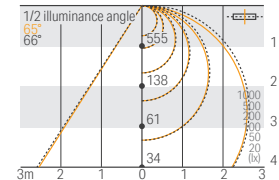

LFUY-T1000**WW-DF-I-20
Light source color 3500K
Brightness 550 cd
Luminous flux 2111 lm
Color rendering index Ra 97

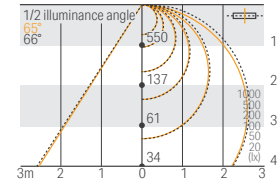

LFUY-T1000**L30-DF-I-20
Light source color 3000K
Brightness 535 cd
Luminous flux 2053 lm
Color rendering index Ra 95

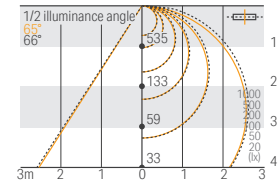

LFUY-T1000**L27-DF-I-20
Light source color 2700K
Brightness 505 cd
Luminous flux 1936 lm
Color rendering index Ra 94

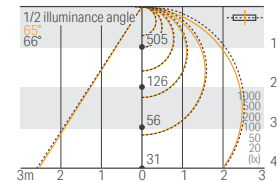

LFUY-T1000**L25-DF-I-20
Light source color 2500K
Brightness 374 cd
Luminous flux 1433 lm
Color rendering index Ra 94

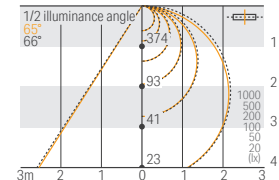

LFUY-T1000**L22-DF-I-20
Light source color 2200K
Brightness 348 cd
Luminous flux 1336 lm
Color rendering index Ra 93

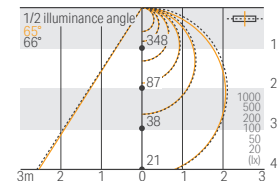

LFUY-T1000**L20-DF-I-20
Light source color 2000K
Brightness 318 cd
Luminous flux 1220 lm
Color rendering index Ra 91

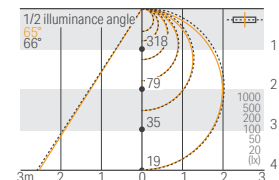



LFUAY Luci SHIN UQ FLEX α

Color temperature

6500K 5000K 4000K 3500K 3000K 2700K 2500K 2200K 2000K

Direct horizontal surface light intensity distribution chart - 6W

LFUAY-T1000**-D-DF-I-6
Light source color 6500K
Brightness 144 cd
Luminous flux 539 lm
Color rendering index Ra 96

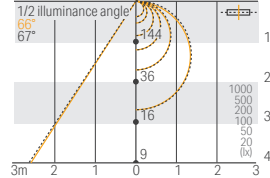

LFUAY-T1000**-N-DF-I-6
Light source color 5000K
Brightness 140 cd
Luminous flux 534 lm
Color rendering index Ra 93

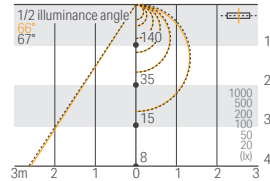

LFUAY-T1000**-W-DF-I-6
Light source color 4000K
Brightness 137 cd
Luminous flux 524 lm
Color rendering index Ra 97

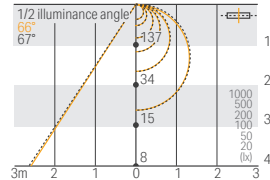

LFUAY-T1000**-WW-DF-I-6
Light source color 3500K
Brightness 136 cd
Luminous flux 520 lm
Color rendering index Ra 97

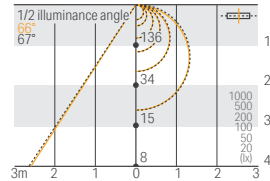

LFUAY-T1000**-L30-DF-I-6
Light source color 3000K
Brightness 132 cd
Luminous flux 505 lm
Color rendering index Ra 95

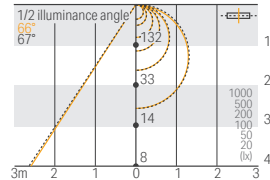

LFUAY-T1000**-L27-DF-I-6
Light source color 2700K
Brightness 125 cd
Luminous flux 477 lm
Color rendering index Ra 94

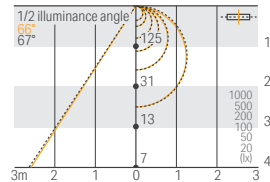

LFUAY-T1000**-L25-DF-I-6
Light source color 2500K
Brightness 92 cd
Luminous flux 353 lm
Color rendering index Ra 94

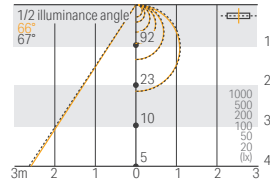

LFUAY-T1000**-L22-DF-I-6
Light source color 2200K
Brightness 86 cd
Luminous flux 329 lm
Color rendering index Ra 93

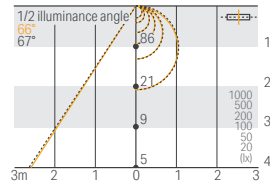

LFUAY-T1000**-L20-DF-I-6
Light source color 2000K
Brightness 79 cd
Luminous flux 300 lm
Color rendering index Ra 91

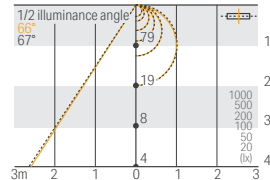

Direct horizontal surface light intensity distribution chart - 10W

LFUAY-T1000**-D-DF-I-10
Light source color 6500K
Brightness 224 cd
Luminous flux 898 lm
Color rendering index Ra 96

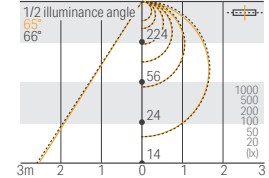

LFUAY-T1000**-N-DF-I-10
Light source color 5000K
Brightness 218 cd
Luminous flux 890 lm
Color rendering index Ra 93

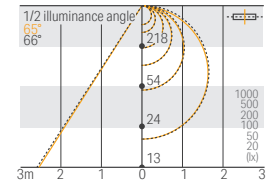

LFUAY-T1000**-W-DF-I-10
Light source color 4000K
Brightness 214 cd
Luminous flux 874 lm
Color rendering index Ra 97

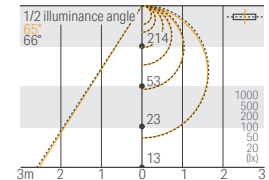

LFUAY-T1000**-WW-DF-I-10
Light source color 3500K
Brightness 212 cd
Luminous flux 866 lm
Color rendering index Ra 97

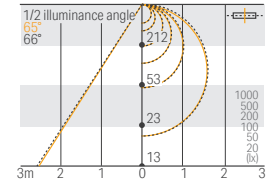

LFUAY-T1000**-L30-DF-I-10
Light source color 3000K
Brightness 206 cd
Luminous flux 842 lm
Color rendering index Ra 95

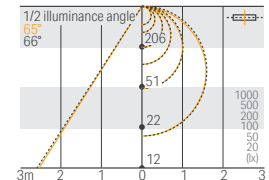

LFUAY-T1000**-L27-DF-I-10
Light source color 2700K
Brightness 194 cd
Luminous flux 794 lm
Color rendering index Ra 94

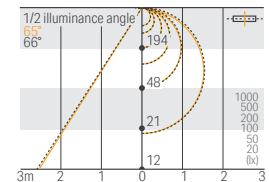

LFUAY-T1000**-L25-DF-I-10
Light source color 2500K
Brightness 144 cd
Luminous flux 588 lm
Color rendering index Ra 94

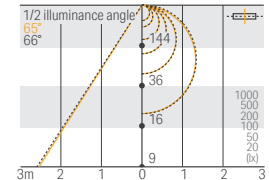

LFUAY-T1000**-L22-DF-I-10
Light source color 2200K
Brightness 134 cd
Luminous flux 548 lm
Color rendering index Ra 93

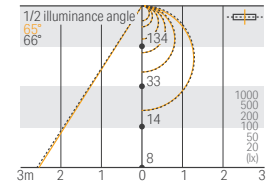

LFUAY-T1000**-L20-DF-I-10
Light source color 2000K
Brightness 122 cd
Luminous flux 500 lm
Color rendering index Ra 91

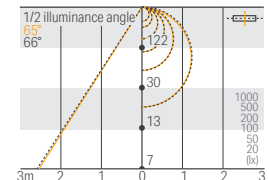

Illuminance data



LFUAY
Luci SHIN UQ FLEX α

Color temperature

6500K 5000K 4000K 3500K 3000K 2700K 2500K 2200K 2000K

Direct horizontal surface light intensity distribution chart - 15W

LFUAY-T1000**-D-DF-I-15
Light source color 6500K
Brightness 310 cd
Luminous flux 1353 lm
Color rendering index Ra 96

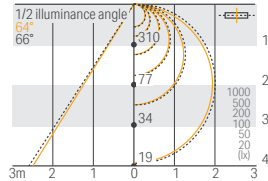

LFUAY-T1000**-N-DF-I-15
Light source color 5000K
Brightness 302 cd
Luminous flux 1341 lm
Color rendering index Ra 93

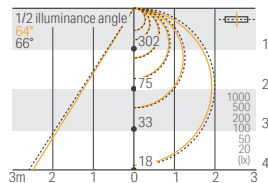

LFUAY-T1000**-W-DF-I-15
Light source color 4000K
Brightness 296 cd
Luminous flux 1318 lm
Color rendering index Ra 97

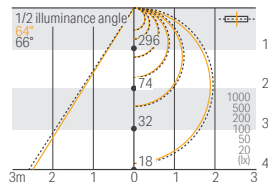

LFUAY-T1000**-WW-DF-I-15
Light source color 3500K
Brightness 294 cd
Luminous flux 1306 lm
Color rendering index Ra 97

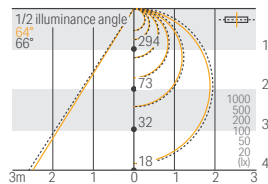

LFUAY-T1000**-L30-DF-I-15
Light source color 3000K
Brightness 286 cd
Luminous flux 1270 lm
Color rendering index Ra 95

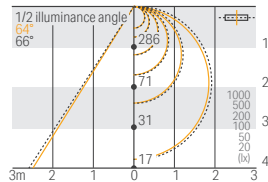

LFUAY-T1000**-L27-DF-I-15
Light source color 2700K
Brightness 269 cd
Luminous flux 1198 lm
Color rendering index Ra 94

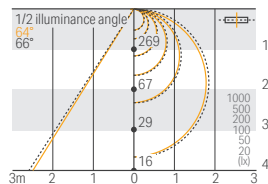

LFUAY-T1000**-L25-DF-I-15
Light source color 2500K
Brightness 199 cd
Luminous flux 886 lm
Color rendering index Ra 94

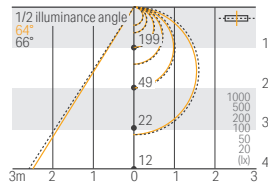

LFUAY-T1000**-L22-DF-I-15
Light source color 2200K
Brightness 186 cd
Luminous flux 826 lm
Color rendering index Ra 93

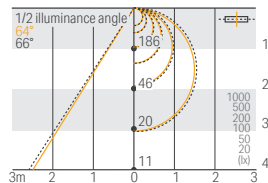

LFUAY-T1000**-L20-DF-I-15
Light source color 2000K
Brightness 170 cd
Luminous flux 755 lm
Color rendering index Ra 91

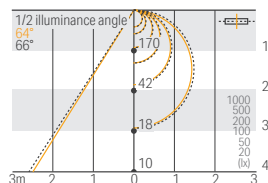

Direct horizontal surface light intensity distribution chart - 20W

LFUAY-T1000**-D-DF-I-20
Light source color 6500K
Brightness 413 cd
Luminous flux 1649 lm
Color rendering index Ra 96

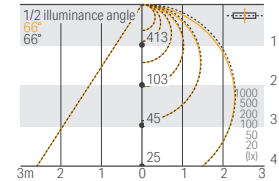

LFUAY-T1000**-N-DF-I-20
Light source color 5000K
Brightness 403 cd
Luminous flux 1635 lm
Color rendering index Ra 93

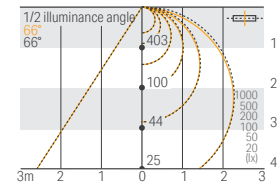

LFUAY-T1000**-W-DF-I-20
Light source color 4000K
Brightness 395 cd
Luminous flux 1605 lm
Color rendering index Ra 97

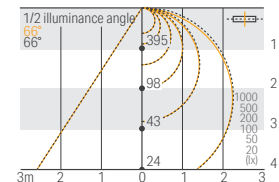

LFUAY-T1000**-WW-DF-I-20
Light source color 3500K
Brightness 392 cd
Luminous flux 1591 lm
Color rendering index Ra 97

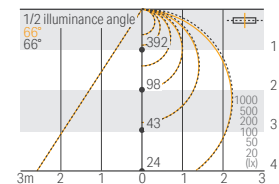

LFUAY-T1000**-L30-DF-I-20
Light source color 3000K
Brightness 381 cd
Luminous flux 1547 lm
Color rendering index Ra 95

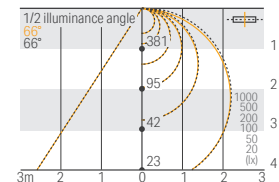

LFUAY-T1000**-L27-DF-I-20
Light source color 2700K
Brightness 359 cd
Luminous flux 1460 lm
Color rendering index Ra 94

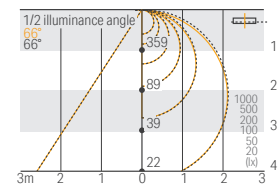

LFUAY-T1000**-L25-DF-I-20
Light source color 2500K
Brightness 266 cd
Luminous flux 1080 lm
Color rendering index Ra 94

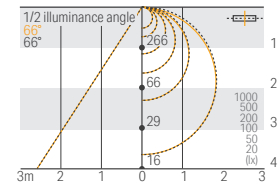

LFUAY-T1000**-L22-DF-I-20
Light source color 2200K
Brightness 248 cd
Luminous flux 1007 lm
Color rendering index Ra 93

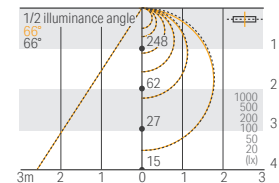

LFUAY-T1000**-L20-DF-I-20
Light source color 2000K
Brightness 226 cd
Luminous flux 920 lm
Color rendering index Ra 91

