

Luci SHIN Creide® F / Luci SHIN Creide® lens

# LCEY / LCELY **SHIN** series **NEW**



Ibaraki Western Medical Center  
Location: Japan  
Architect office: YAMASHITA NEMOTOHIDE SEKKEI JV

Lighting Design: YAMASHITA SEKKEI INC.  
Construction: MAEDA CORPORATION  
Photo: Ca'd'Oro/SASAKI TOSHINORI



TRUSCO NAKAYAMA KYOTO KAGURAOKA RENGETSOU  
Location: Japan  
Architect office: NIKKEN SEKKEI LTD.  
Photo: Kouji Horiuchi

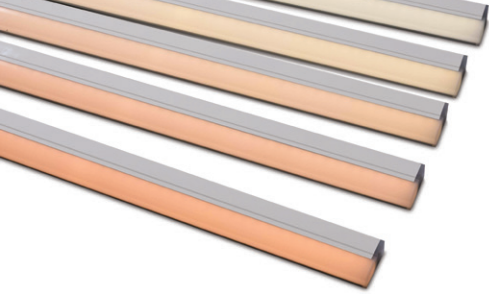

# Luci SHIN Creide® / Luci SHIN Creide® lens

Updated with high efficacy LED series and 2 wattage variations

LCEY:

For cove and wall grazer light with only 17.4mm height easy to be hidden

Wider spread angle with diffuser cover

LCELY:

Narrower spread angle with the lens in diffused cover

Indoor

Rigid light

LCEY / LCELY

SHIN Creide® / SHIN Creide® lens

## Specifications

### Dimensions

Cross section W 42.5 x H 17.4 mm  
Length 14 types of fixed length

1410	1310	1210	1110	1010	910
810	710	610	510	410	310
210	110	(mm)			

## Features

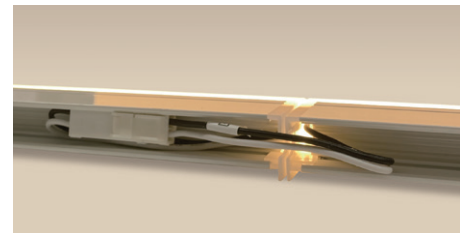
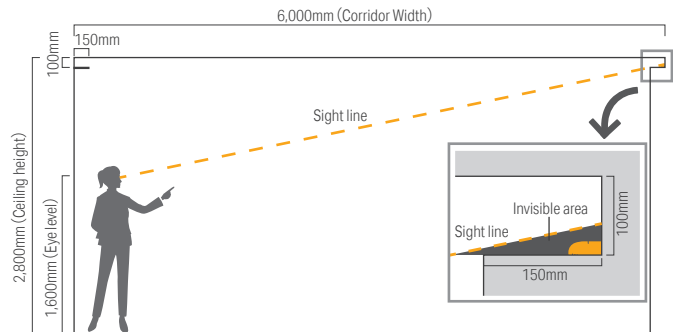

Connectors are concealed behind lighting fixtures

## Electrical & Output @2700K

LCEF			SHIN series LCEY			Efficacy Improvement
W/m	lm/m	lm/W	W/m	lm/m	lm/W	
21.0 W/m	1021 lm/m	49 lm/W	10.7 W/m	982 lm/m	91.4 lm/W	189%
			15.8 W/m	1416 lm/m	89.5 lm/W	
LCEL			SHIN series LCELY			
W/m	lm/m	lm/W	W/m	lm/m	lm/W	
20.7 W/m	1179 lm/m	57 lm/W	10.7 W/m	959 lm/m	89.2 lm/W	157%
			15.8 W/m	1386 lm/m	87.6 lm/W	

## Color temperature

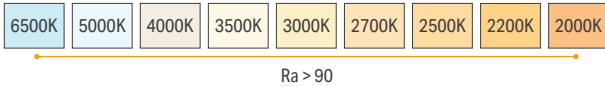

## Light distribution

### Luci SHIN Creide®

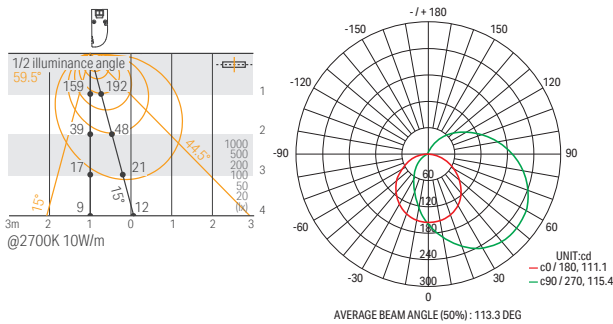
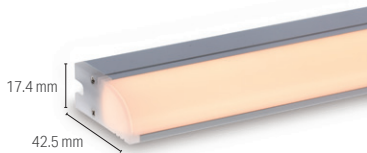

### Luci SHIN Creide® lens

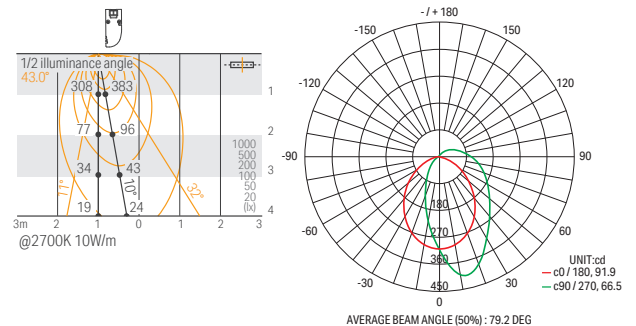

Hotel Asia Center of Japan  
Location: Japan  
Architect office: Fukuoka Urban Laboratory LLC + SHOWA Interior & Facilities Industry CO., LTD.  
Lighting Design, Construction: SHOWA Interior & Facilities Industry CO., LTD.

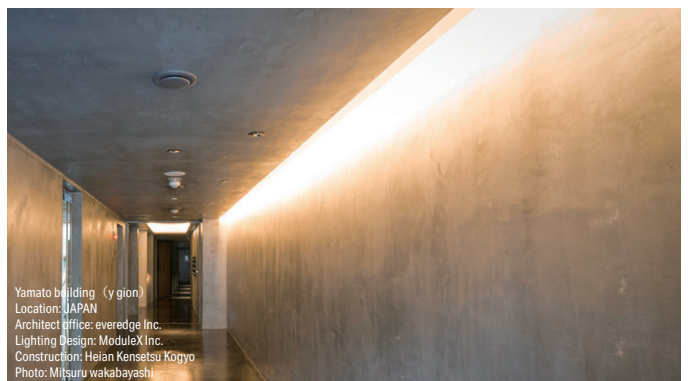

Yamato building (Y-gion)  
Location: JAPAN  
Architect office: everedge Inc.  
Lighting Design: ModuleX Inc.  
Construction: Heian Kensetsu Kogyo  
Photo: Mihsuru wakabayashi



# LCEY **SHIN** series NEW

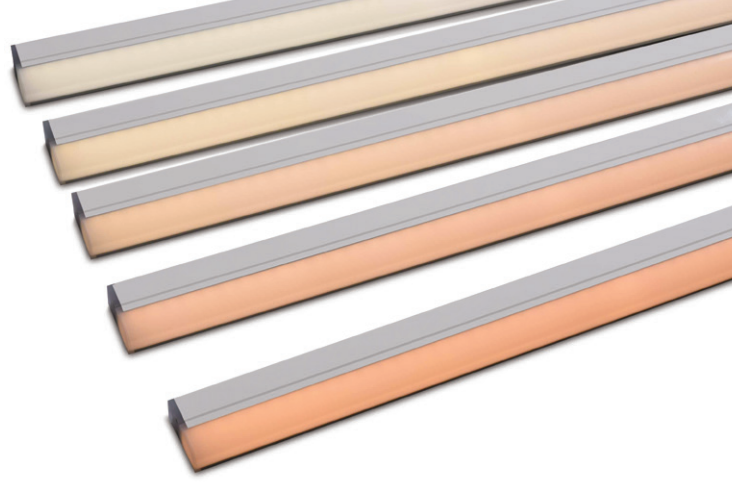

Color management  
MacAdam 3 step CE

- Updated with high efficacy LED series and 2 wattage variations
- Increased 180% efficacy
- For cove and wall grazer light with only 17.4mm height easy to be hidden
- Wider spread angle with diffuser cover

Model No.

**LCEY** -      -   - **DF** - **I** -  

Product Name	Length	Light source color	Cover Type	Environment	Wattage
LCEY	0110 0810 0210 0910 0310 1010 0410 1110 0510 1210 0610 1310 0710 1410	D : 6500K L30 : 3000K N : 5000K L27 : 2700K W : 4000K L25 : 2500K WW : 3500K L22 : 2200K L20 : 2000K	DF : Diffuser	I : Indoor	10 : 10.7 W/m 15 : 15.8 W/m

### Specification

Model No.	LCEY-(Length)-(Light source color)-DF-I-(Wattage)			
Wattage(Code)			10	15
Wattage			10.7 W/m	15.8 W/m
Luminaire efficacy @2700K			91.4 lm/W	89.5 lm/W
Luman output				
Light source color(Code)	CRI	Luminaire flux		
D	6500K Ra 96	1110 lm/m	1600 lm/m	
N	5000K Ra 93	1100 lm/m	1586 lm/m	
W	4000K Ra 97	1081 lm/m	1557 lm/m	
WW	3500K Ra 97	1071 lm/m	1543 lm/m	
L30	3000K Ra 95	1041 lm/m	1501 lm/m	
L27	2700K Ra 94	982 lm/m	1416 lm/m	
L25	2500K Ra 94	727 lm/m	1048 lm/m	
L22	2200K Ra 93	678 lm/m	977 lm/m	
L20	2000K Ra 91	619 lm/m	892 lm/m	

### General Specification

Input voltage	DC24V
Environment	Indoors (no condensation)
Max. length per circuit	5m
Material	Body : aluminum , Cover : polycarbonate
Attachments	① Mounting clip 1pc - 0110, 0210 2pcs - 0310, 0410, 0510, 0610, 0710 3pcs - 0810, 0910, 1010, 1110 4pcs - 1210, 1310, 1410
Accessories	① Mounting clip ② Outerclip ③ ④ Magnet set ⑤ Power supply cable ⑥ Joint cable
Certification	CE
Dimmable	Yes (0-10V, 1-10V, DMX, DALI, PWM, Casambi)

### External dimensions

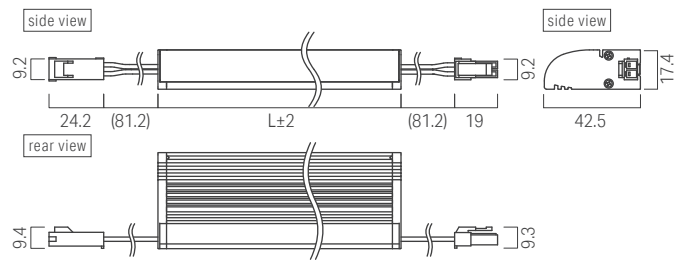

### Luminous intensity distribution

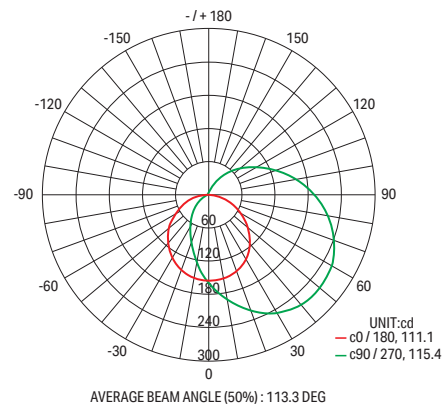

Length(Code)	Fitting length(mm)	Weigth(g)	Wattage(Code)	
			10	15
			Wattage (W)	
0110	110.6	45	1.1	1.6
0210	210.6	90	2.1	3.2
0310	310.6	135	3.2	4.7
0410	410.6	175	4.3	6.3
0510	510.6	215	5.4	7.9
0610	610.6	255	6.4	9.5
0710	710.6	295	7.5	11.1
0810	810.6	335	8.6	12.7
0910	910.6	375	9.7	14.2
1010	1010.6	415	10.7	15.8
1110	1110.6	455	11.8	17.4
1210	1210.6	495	12.9	19.0
1310	1310.6	535	14.0	20.6
1410	1410.6	575	15.0	22.1

### Max. connectable length per PSU

Length of light fixture (70% loading factor) During dimmer use *: split into multiple circuits		PSU
10.7 W/m	15.8 W/m	
~3.3m	~2.2m	50W
~6.5m*	~4.4m	100W
~9.8m*	~6.6m*	150W

Cross sectional view with accessories

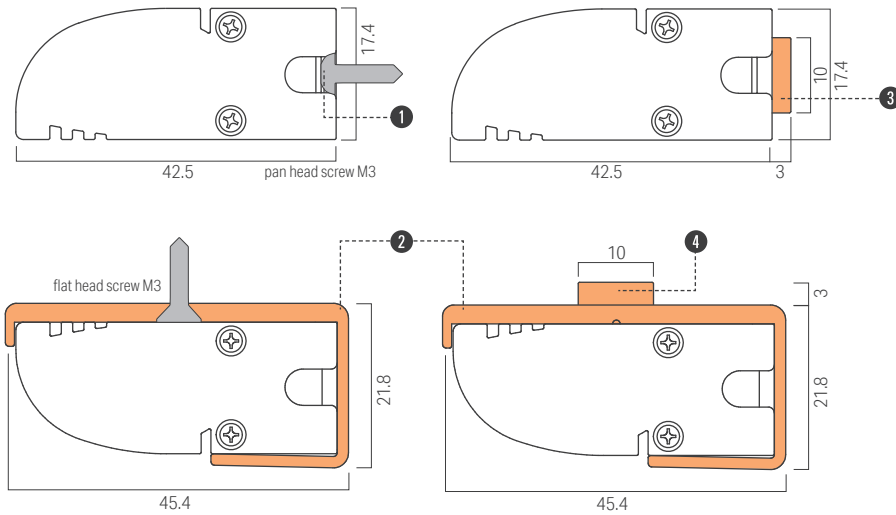

Accessories

1 Mounting clip A for Creide **Attachments**



Model No : LCE-PT-A  
Attached with light fixture  
1pc - 0110, 0210  
2pcs - 0310, 0410, 0510, 0610, 0710  
3pcs - 0810, 0910, 1010, 1110  
4pcs - 1210, 1310, 1410

For extra order  
2 pcs / bag

For magnet installation,  
please refer to the required number  
of clips in the product catalog.

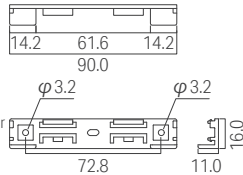

2 Outer clip for Creide



Model No : LCE-PT-B  
2 pcs/bag  
Recommended number  
1pc - 0110, 0210  
2pcs - 0310, 0410  
3pcs - 0510, 0610, 0710  
4pcs - 0810, 0910, 1010, 1110, 1210  
5pcs - 1310, 1410

For magnet installation,  
please refer to the required number  
of clips in the product catalog.

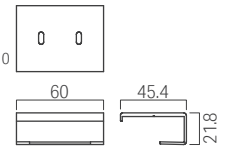

3 Magnet Set L



Model No : MG-L  
10 sets/bag  
Required 2 pcs per Mounting clip A

Used for installing light fixture with 1 Mounting clip A on metal plate.  
Metal plate is required by installer.

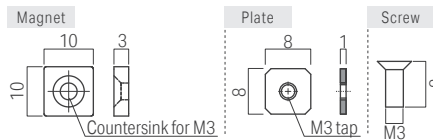

4 Magnet Set A



Model No : MG-A  
5 sets/bag  
Required 2 pcs per Outer clip

Used for installing light fixture with 2 Outer clip for Creide on metal plate.  
Metal plate is required by installer.

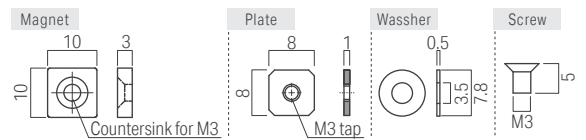

5 Power supply cable 3M



Model No : CAD-3000-MCNN-I

1 pcs per circuit for connecting the light fixture  
to power supply or dimmer driver.

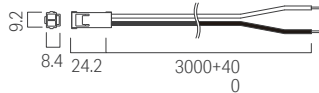

Recommended No. of clips & magnets

Length	0110	0210	0310	0410	0510	0610	0710	0810	0910	1010	1110	1210	1310	1410	
<b>Attachments</b>															
Mounting clip A	1 pc	1 pc	2 pcs	2 pcs	2 pcs	2 pcs	2 pcs	3 pcs	3 pcs	3 pcs	3 pcs	4 pcs	4 pcs	4 pcs	Unit of order
Recommended No. of 1 Mounting clip A	1 pc	1 pc	2 pcs	2 pcs	2 pcs	2 pcs	2 pcs	3 pcs	3 pcs	3 pcs	3 pcs	4 pcs	4 pcs	4 pcs	2 pcs/bag
Extra															
1 Mounting clip A for magnet installation	0 pc	0 pc	0 pc	0 pc	1 pc	1 pc	1 pc	1 pc	1 pc	1 pc	1 pc	1 pc	1 pc	1 pc	2 pcs/bag
2 Magnet set L	2 pcs	2 pcs	4 pcs	4 pcs	6 pcs	6 pcs	6 pcs	8 pcs	8 pcs	8 pcs	8 pcs	10 pcs	10 pcs	10 pcs	10 pcs/bag
Recommended No. of 2 Outer clip	1 pc	1 pc	2 pcs	2 pcs	3 pcs	3 pcs	3 pcs	4 pcs	4 pcs	4 pcs	4 pcs	4 pcs	5 pcs	5 pcs	2 pcs/bag
3 Magnet set A	2 pcs	2 pcs	4 pcs	4 pcs	6 pcs	6 pcs	6 pcs	8 pcs	8 pcs	8 pcs	8 pcs	8 pcs	10 pcs	10 pcs	5 pcs/bag



# LCELY **SHIN** series NEW

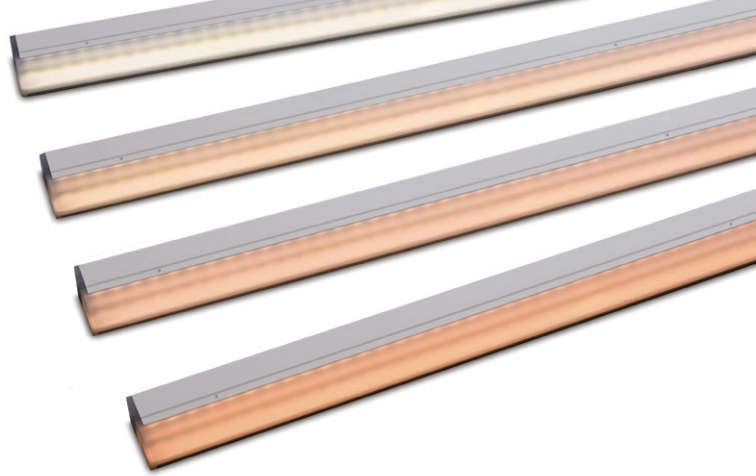

Color management  
MacAdam 3 step CE

- Updated with low wattage high lumen LED series and 2 wattage variations
- Increased 160% efficacy
- Narrower spread angle with the lens in diffused cover

Model No.

**LCELY** -             -    - **DF** - **I** -   

Product Name	Length	Light source color	Cover Type	Environment	Wattage
LCELY	0110 0810 0210 0910 0310 1010 0410 1110 0510 1210 0610 1310 0710 1410	D : 6500K L30 : 3000K N : 5000K L27 : 2700K W : 4000K L25 : 2500K WW : 3500K L22 : 2200K L20 : 2000K	DF : Diffuser	I : Indoor	10 : 10.7 W/m 15 : 15.8 W/m

### Specification

Model No.	LCELY-(Length)-(Light source color)-DF-I-(Wattage)			
Wattage(Code)			10	15
Wattage			10.7 W/m	15.8 W/m
Luminaire efficacy @2700K			89.2 lm/W	87.6 lm/W
Luman output				
Light source color(Code)	CRI	Luminaire flux		
D	6500K Ra 96	1083 lm/m	1566 lm/m	
N	5000K Ra 93	1074 lm/m	1552 lm/m	
W	4000K Ra 97	1055 lm/m	1524 lm/m	
WW	3500K Ra 97	1045 lm/m	1510 lm/m	
L30	3000K Ra 95	1016 lm/m	1469 lm/m	
L27	2700K Ra 94	959 lm/m	1386 lm/m	
L25	2500K Ra 94	710 lm/m	1025 lm/m	
L22	2200K Ra 93	662 lm/m	956 lm/m	
L20	2000K Ra 91	604 lm/m	873 lm/m	

### General Specification

Input voltage	DC24V
Environment	Indoors (no condensation)
Max. length per circuit	5m
Material	Body : aluminum , Cover : polycarbonate
Attachments	① Mounting clip 1pc - 0110, 0210 2pcs - 0310, 0410, 0510, 0610, 0710 3pcs - 0810, 0910, 1010, 1110 4pcs - 1210, 1310, 1410
Accessories	① Mounting clip ② Outerclip ③ ④ Magnet set ⑤ Power supply cable ⑥ Joint cable
Certification	CE
Dimmable	Yes (0-10V, 1-10V, DMX, DALI, PWM, Casambi)

Length(Code)	Fitting length(mm)	Weigth(g)	Wattage(Code)	
			10	15
			Wattage (W)	
0110	110.6	50	1.1	1.6
0210	210.6	95	2.1	3.2
0310	310.6	140	3.2	4.7
0410	410.6	180	4.3	6.3
0510	510.6	220	5.4	7.9
0610	610.6	260	6.4	9.5
0710	710.6	300	7.5	11.1
0810	810.6	340	8.6	12.7
0910	910.6	380	9.7	14.2
1010	1010.6	420	10.7	15.8
1110	1110.6	460	11.8	17.4
1210	1210.6	500	12.9	19.0
1310	1310.6	540	14.0	20.6
1410	1410.6	580	15.0	22.1

### External dimensions

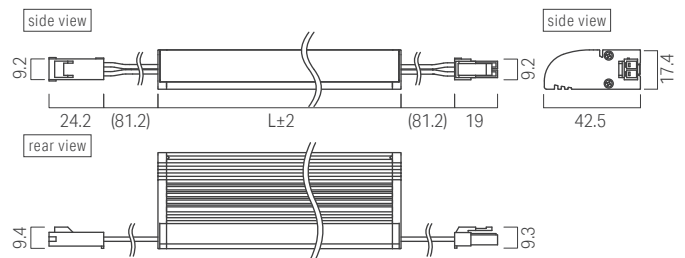

### Luminous intensity distribution

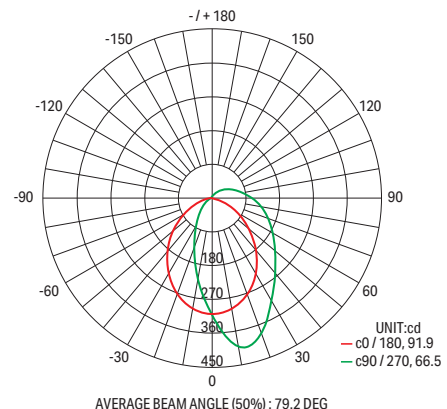

### Max. connectable length per PSU

Length of light fixture (70% loading factor) During dimmer use *: split into multiple circuits		PSU
10.7 W/m	15.8 W/m	
~3.3m	~2.2m	50W
~6.5m*	~4.4m	100W
~9.8m*	~6.6m*	150W

Cross sectional view with accessories

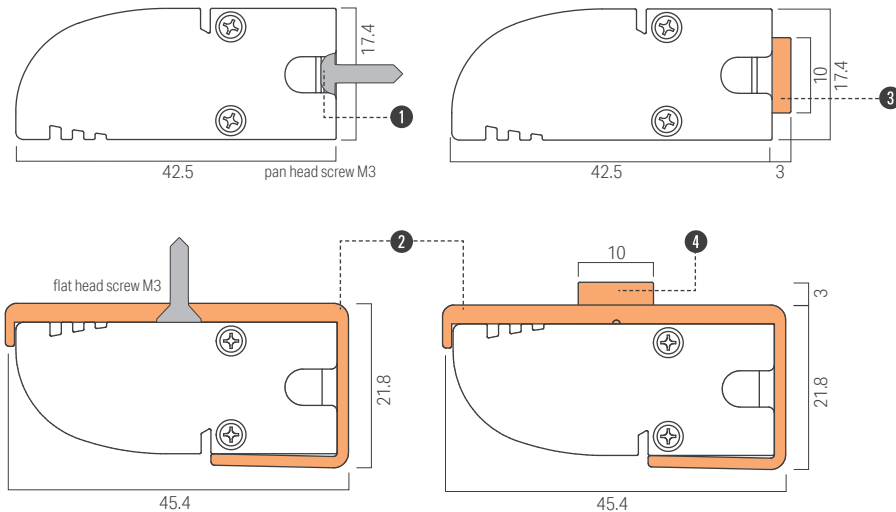

Accessories

1 Mounting clip A for Creide **Attachments**



Model No : LCE-PT-A  
Attached with light fixture  
1pc - 0110, 0210  
2pcs - 0310, 0410, 0510, 0610, 0710  
3pcs - 0810, 0910, 1010, 1110  
4pcs - 1210, 1310, 1410

For extra order  
2 pcs / bag

For magnet installation,  
please refer to the required number  
of clips in the product catalog.

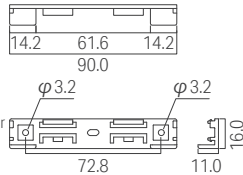

2 Outer clip for Creide



Model No : LCE-PT-B  
2 pcs/bag  
Recommended number  
1pc - 0110, 0210  
2pcs - 0310, 0410  
3pcs - 0510, 0610, 0710  
4pcs - 0810, 0910, 1010, 1110, 1210  
5pcs - 1310, 1410

For magnet installation,  
please refer to the required number  
of clips in the product catalog.

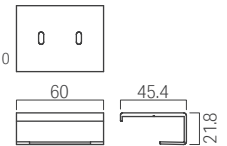

3 Magnet Set L



Model No : MG-L  
10 sets/bag  
Required 2 pcs per Mounting clip A

Used for installing light fixture with 1 Mounting clip A on metal plate.  
Metal plate is required by installer.

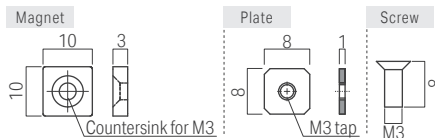

4 Magnet Set A



Model No : MG-A  
5 sets/bag  
Required 2 pcs per Outer clip

Used for installing light fixture with 2 Outer clip for Creide on metal plate.  
Metal plate is required by installer.

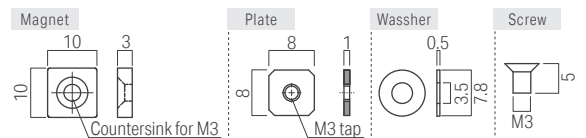

5 Magnet Set L



Model No : CAD-3000-MCNN-I  
1 pcs per circuit for connecting the light fixture  
to power supply or dimmer driver.

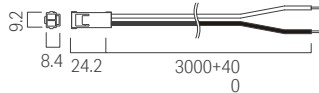

Recommended No. of clips & magnets

Length	0110	0210	0310	0410	0510	0610	0710	0810	0910	1010	1110	1210	1310	1410	
<b>Attachments</b>															
Mounting clip A	1 pc	1 pc	2 pcs	2 pcs	2 pcs	2 pcs	2 pcs	3 pcs	3 pcs	3 pcs	3 pcs	4 pcs	4 pcs	4 pcs	Unit of order
Recommended No. of 1 Mounting clip A	1 pc	1 pc	2 pcs	2 pcs	2 pcs	2 pcs	2 pcs	3 pcs	3 pcs	3 pcs	3 pcs	4 pcs	4 pcs	4 pcs	2 pcs/bag
Extra															
1 Mounting clip A for magnet installation	0 pc	0 pc	0 pc	0 pc	1 pc	1 pc	1 pc	1 pc	1 pc	1 pc	1 pc	1 pc	1 pc	1 pc	2 pcs/bag
2 Magnet set L	2 pcs	2 pcs	4 pcs	4 pcs	6 pcs	6 pcs	6 pcs	8 pcs	8 pcs	8 pcs	8 pcs	10 pcs	10 pcs	10 pcs	10 pcs/bag
Recommended No. of 2 Outer clip	1 pc	1 pc	2 pcs	2 pcs	3 pcs	3 pcs	3 pcs	4 pcs	4 pcs	4 pcs	4 pcs	4 pcs	5 pcs	5 pcs	2 pcs/bag
3 Magnet set A	2 pcs	2 pcs	4 pcs	4 pcs	6 pcs	6 pcs	6 pcs	8 pcs	8 pcs	8 pcs	8 pcs	8 pcs	10 pcs	10 pcs	5 pcs/bag

## Installing the product

### Mounting clip A installation: behind fixing

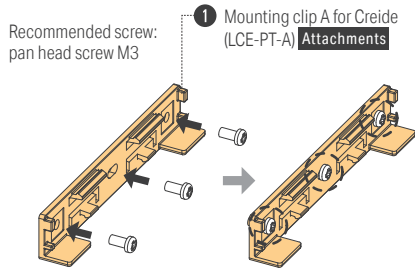

Use three screws per one Mounting clip A.

Recommend to use at least 3 pcs per meter with less than 380mm pitch.

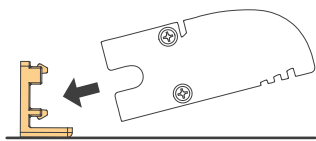
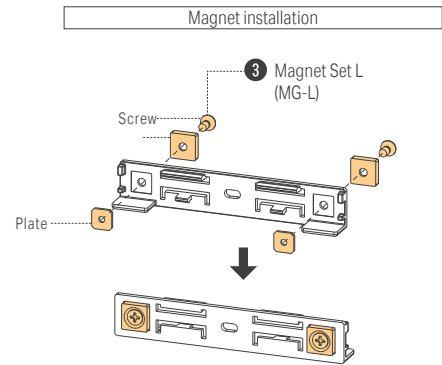

Mounting clips should be installed in the position (as shown above).

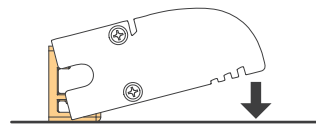

Clasp the light fixture onto the preset mounting clips (a click sound will be produced once it is tightly fastened).

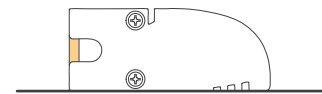

Ensure that there are no gaps in between fixture and surface

### For vertical installation

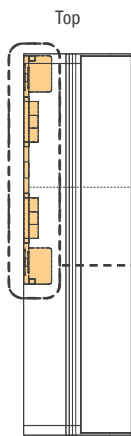

1 Mounting clip A for Creide (LCE-PT-A) Attachments  
For vertical installation, make sure the light fixture hook on the edge of the mounting clip in accordance to the diagram.  
Caution: If the weight of the light fixture is not supported by the edge of the mounting clip, it may slide down and fall.

Recommended screw: pan head screw M3

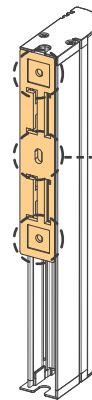

Secure 1 mounting clip with 3 screws  
Caution: If using only 1 or 2 screws, the light fixture may fall since the holding force is not enough.

### Recommended No. of clips & magnets

Length	0110	0210	0310	0410	0510	0610	0710	0810	0910	1010	1110	1210	1310	1410	
Attachment															
Mounting clip A	1 pc	1 pc	2 pcs	2 pcs	2 pcs	2 pcs	2 pcs	3 pcs	3 pcs	3 pcs	3 pcs	4 pcs	4 pcs	4 pcs	Unit of order
Recommended No. of															
1 Mounting clip A	1 pc	1 pc	2 pcs	2 pcs	2 pcs	2 pcs	2 pcs	3 pcs	3 pcs	3 pcs	3 pcs	4 pcs	4 pcs	4 pcs	2 pcs/bag
Extra															
1 Mounting clip A for magnet installation	0 pc	0 pc	0 pc	0 pc	1 pc	1 pc	1 pc	1 pc	1 pc	1 pc	1 pc	1 pc	1 pc	1 pc	2 pcs/bag
3 Magnet set L	2 pcs	2 pcs	4 pcs	4 pcs	6 pcs	6 pcs	6 pcs	8 pcs	8 pcs	8 pcs	8 pcs	10 pcs	10 pcs	10 pcs	10 pcs/bag



Installing the product

Outer clip installation

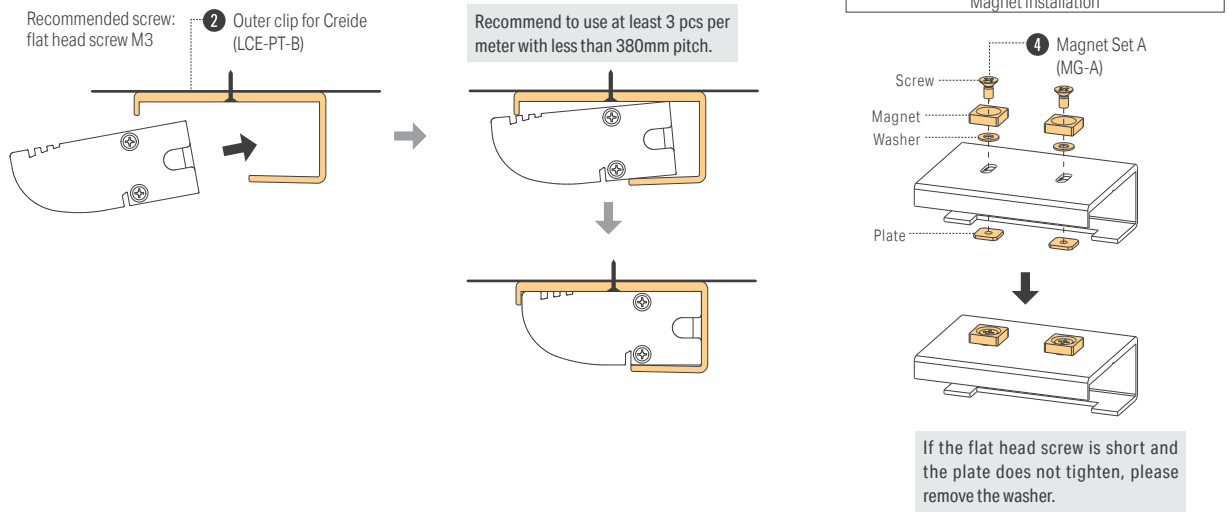

Recommended No. of clips & magnets

Length	0110	0210	0310	0410	0510	0610	0710	0810	0910	1010	1110	1210	1310	1410	
Recommended No. of ② Outer clip	1 pc	1 pc	2 pcs	2 pcs	3 pcs	3 pcs	3 pcs	4 pcs	4 pcs	4 pcs	4 pcs	4 pcs	5 pcs	5 pcs	2 pcs/bag
④ Magnet set A	2 pcs	2 pcs	4 pcs	4 pcs	6 pcs	6 pcs	6 pcs	8 pcs	8 pcs	8 pcs	8 pcs	8 pcs	10 pcs	10 pcs	5 pcs/bag

System configuration diagram

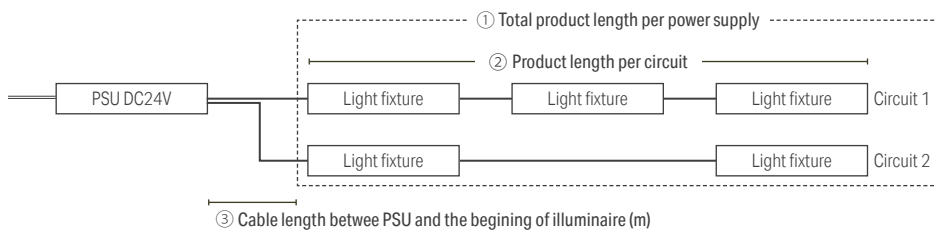

- ① Total product length per PSU depends on capacity of the PSU. Recommended loading factor is 70% (without dimming) or 60% (with dimming).
- ② Product length per circuit shall not exceed maximum product length per circuit. If the product length per circuit exceeds the maximum, split into multiple circuits.
- ③ To minimize voltage drop, select appropriate wire gauge / diameter and consider the cable length between PSU and the beginning of luminaire referring to the following table. If longer cable distances are required, use thicker wires or reduce the loading of the light fixtures in the circuit.

① Max. connectable length per PSU

Length of light fixture (70% loading factor) *: split into multiple circuits		PSU
10.7 W/m	15.8 W/m	
~3.3m	~2.2m	50W
~6.5m*	~4.4m	100W
~9.8m*	~6.6m*	150W

Model No.	Wattage	Cross section	0.3 sq	0.5 sq	0.75 sq
		Wire gauze	AWG 22	AWG 20	AWG 18
		② Max length per circuit	③ Max cable length between PSU and the top of illuminaire at ② Max length per circuit		
LCEY/LCELY-**-DF-I-10	10.7 W/m	5 m	3 m	5 m	7.7 m
LCEY/LCELY-**-DF-I-15	15.8 W/m	5 m	2 m	3.3 m	5.2 m

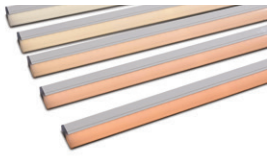

# LCEY Luci SHIN Creide

Color temperature

6500K 5000K 4000K 3500K 3000K 2700K 2500K 2200K 2000K

## Direct horizontal surface light intensity distribution chart - 10W

### LCEY-1010-D-DF-I-10

Light source color 6500K  
Brightness 182 cd  
Luminous flux 1110 lm  
Color rendering index Ra 96

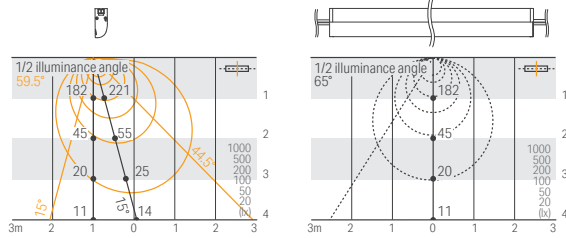

### LCEY-1010-N-DF-I-10

Light source color 5000K  
Brightness 178 cd  
Luminous flux 1100 lm  
Color rendering index Ra 93

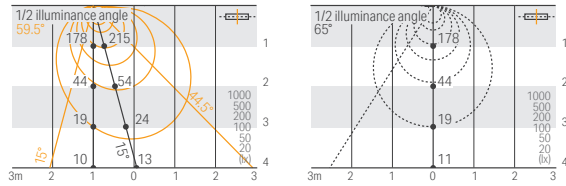

### LCEY-1010-W-DF-I-10

Light source color 4000K  
Brightness 144 cd  
Luminous flux 1081 lm  
Color rendering index Ra 97

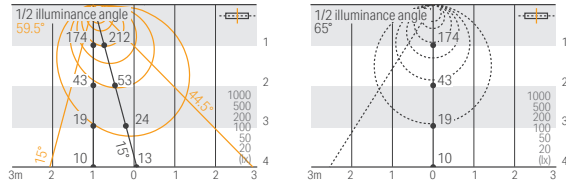

### LCEY-1010-WW-DF-I-10

Light source color 3500K  
Brightness 173 cd  
Luminous flux 1071 lm  
Color rendering index Ra 97

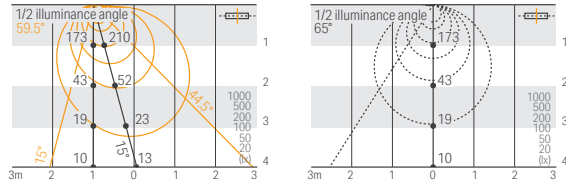

### LCEY-1010-L30-DF-I-10

Light source color 3000K  
Brightness 168 cd  
Luminous flux 1041 lm  
Color rendering index Ra 95

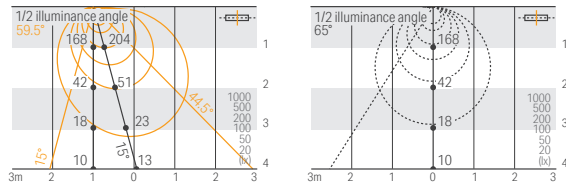

### LCEY-1010-L27-DF-I-10

Light source color 2700K  
Brightness 159 cd  
Luminous flux 982 lm  
Color rendering index Ra 94

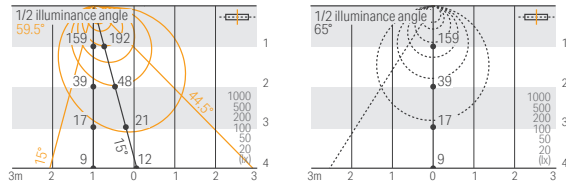

### LCEY-1010-L25-DF-I-10

Light source color 2500K  
Brightness 117 cd  
Luminous flux 727 lm  
Color rendering index Ra 94

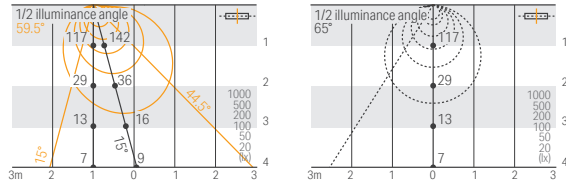

### LCEY-1010-L22-DF-I-10

Light source color 2200K  
Brightness 109 cd  
Luminous flux 378 lm  
Color rendering index Ra 93

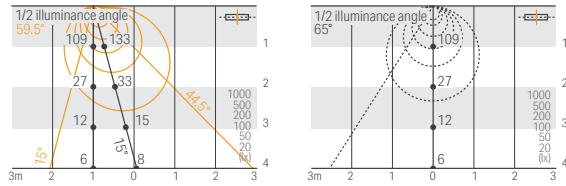

### LCEY-1010-L20-DF-I-10

Light source color 2000K  
Brightness 100 cd  
Luminous flux 619 lm  
Color rendering index Ra 91

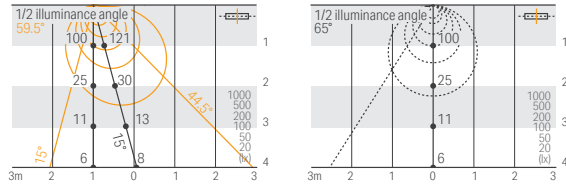

Illuminance data

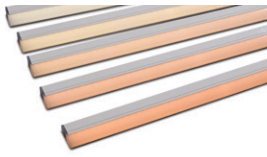

**LCEY**  
Luci SHIN Creide

Color temperature

6500K 5000K 4000K 3500K 3000K 2700K 2500K 2200K 2000K

Direct horizontal surface light intensity distribution chart - 15W

LCEY-1010-D-DF-I-15

Light source color 6500K  
Brightness 267 cd  
Luminous flux 1600 lm  
Color rendering index Ra 96

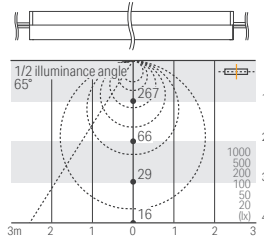
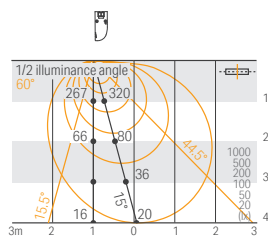

LCEY-1010-N-DF-I-15

Light source color 5000K  
Brightness 260 cd  
Luminous flux 1586 lm  
Color rendering index Ra 93

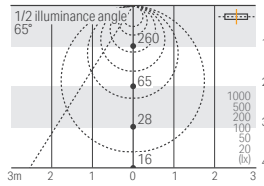
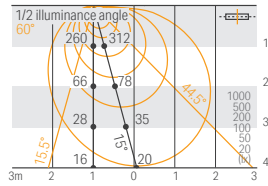

LCEY-1010-W-DF-I-15

Light source color 4000K  
Brightness 255 cd  
Luminous flux 1557 lm  
Color rendering index Ra 97

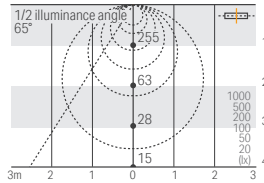
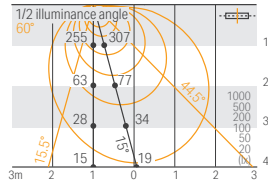

LCEY-1010-WW-DF-I-15

Light source color 3500K  
Brightness 253 cd  
Luminous flux 1543 lm  
Color rendering index Ra 97

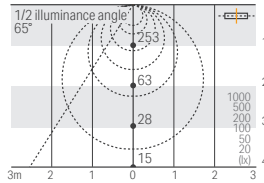
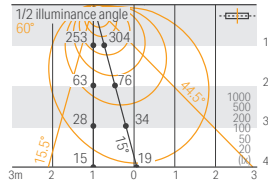

LCEY-1010-L30-DF-I-15

Light source color 3000K  
Brightness 246 cd  
Luminous flux 1501 lm  
Color rendering index Ra 95

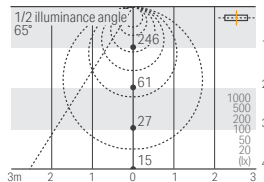
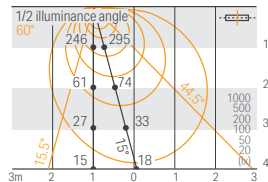

LCEY-1010-L27-DF-I-15

Light source color 2700K  
Brightness 232 cd  
Luminous flux 1416 lm  
Color rendering index Ra 94

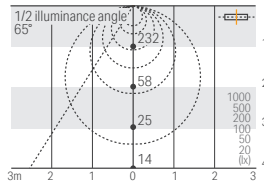
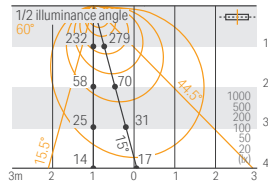

LCEY-1010-L25-DF-I-15

Light source color 2500K  
Brightness 171 cd  
Luminous flux 1048 lm  
Color rendering index Ra 94

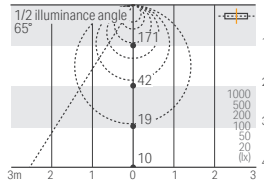
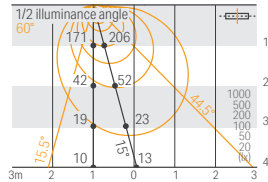

LCEY-1010-L22-DF-I-15

Light source color 2200K  
Brightness 160 cd  
Luminous flux 977 lm  
Color rendering index Ra 93

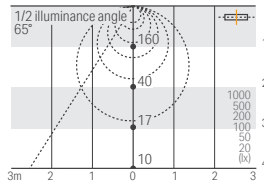
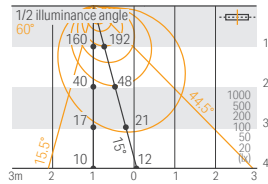

LCEY-1010-L20-DF-I-15

Light source color 2000K  
Brightness 146 cd  
Luminous flux 892 lm  
Color rendering index Ra 91

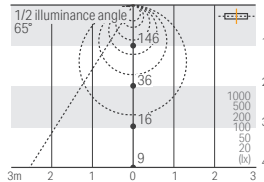
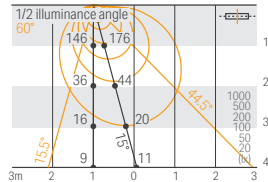



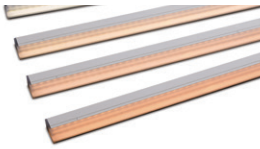

# LCELY Luci SHIN Creide lens

Color temperature

6500K 5000K 4000K 3500K 3000K 2700K 2500K 2200K 2000K

Direct horizontal surface light intensity distribution chart - 10W

### LCELY-1010-D-DF-I-10

Light source color 6500K  
Brightness 355 cd  
Luminous flux 1083 lm  
Color rendering index Ra 96

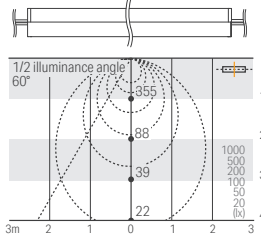
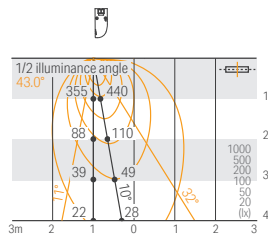

### LCELY-1010-N-DF-I-10

Light source color 5000K  
Brightness 346 cd  
Luminous flux 1074 lm  
Color rendering index Ra 93

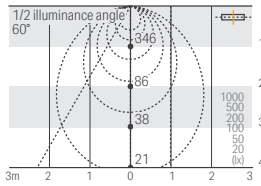
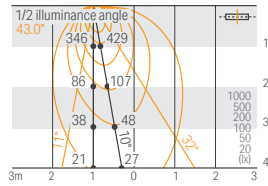

### LCELY-1010-W-DF-I-10

Light source color 4000K  
Brightness 339 cd  
Luminous flux 1055 lm  
Color rendering index Ra 97

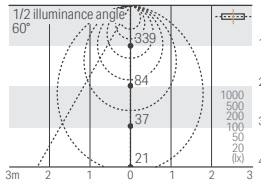
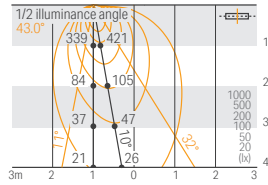

### LCELY-1010-WW-DF-I-10

Light source color 3500K  
Brightness 336 cd  
Luminous flux 1045 lm  
Color rendering index Ra 97

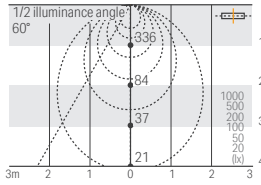
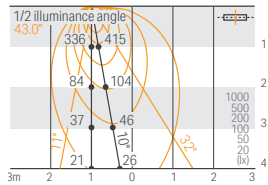

### LCELY-1010-L30-DF-I-10

Light source color 3000K  
Brightness 327 cd  
Luminous flux 1016 lm  
Color rendering index Ra 95

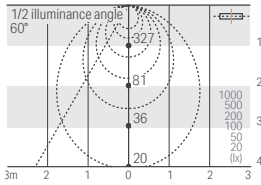
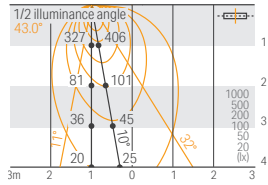

### LCELY-1010-L27-DF-I-10

Light source color 2700K  
Brightness 308 cd  
Luminous flux 959 lm  
Color rendering index Ra 94

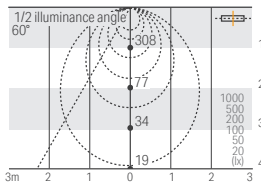
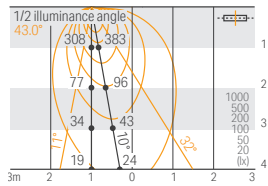

### LCELY-1010-L25-DF-I-10

Light source color 2500K  
Brightness 228 cd  
Luminous flux 710 lm  
Color rendering index Ra 94

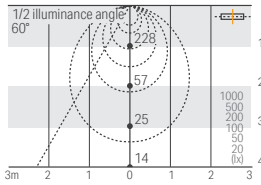
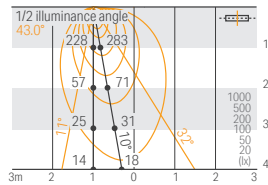

### LCELY-1010-L22-DF-I-10

Light source color 2200K  
Brightness 213 cd  
Luminous flux 662lm  
Color rendering index Ra 93

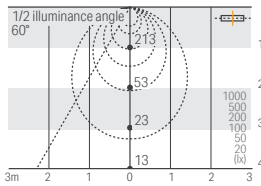
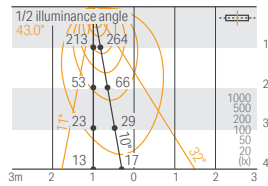

### LCELY-1010-L20-DF-I-10

Light source color 2000K  
Brightness 194 cd  
Luminous flux 604 lm  
Color rendering index Ra 91

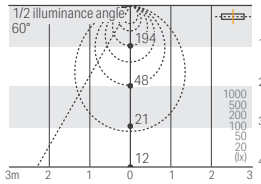
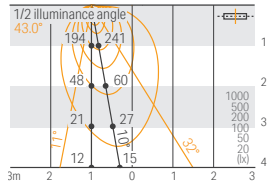

Illuminance data

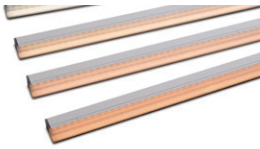

**LCELY**  
Luci SHIN Creide lens

Color temperature

6500K 5000K 4000K 3500K 3000K 2700K 2500K 2200K 2000K

Direct horizontal surface light intensity distribution chart - 15W

LCELY-1010-D-DF-I-15

Light source color 6500K  
Brightness 519 cd  
Luminous flux 1566 lm  
Color rendering index Ra 96

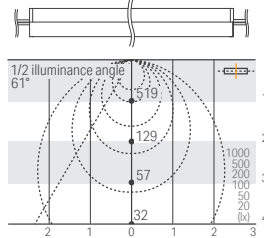
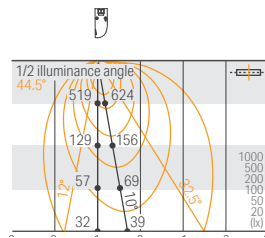

LCELY-1010-N-DF-I-15

Light source color 5000K  
Brightness 506 cd  
Luminous flux 1552 lm  
Color rendering index Ra 93

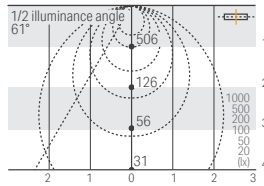
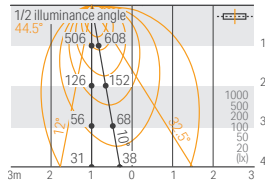

LCELY-1010-W-DF-I-15

Light source color 4000K  
Brightness 497 cd  
Luminous flux 1524 lm  
Color rendering index Ra 97

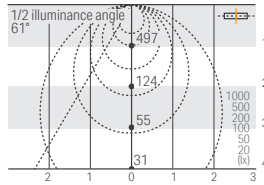
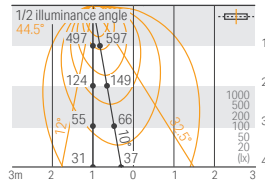

LCELY-1010-WW-DF-I-15

Light source color 3500K  
Brightness 492 cd  
Luminous flux 1510 lm  
Color rendering index Ra 97

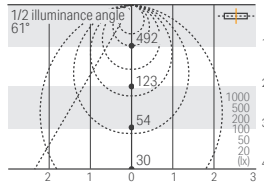
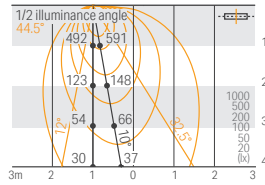

LCELY-1010-L30-DF-I-15

Light source color 3000K  
Brightness 479 cd  
Luminous flux 1469 lm  
Color rendering index Ra 95

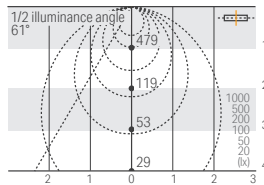
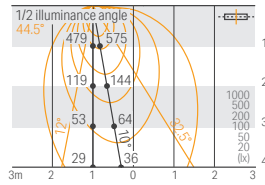

LCELY-1010-L27-DF-I-15

Light source color 2700K  
Brightness 451 cd  
Luminous flux 1386 lm  
Color rendering index Ra 94

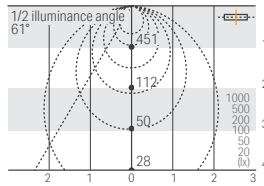
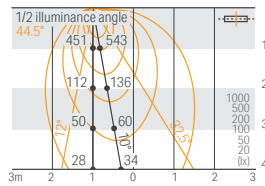

LCELY-1010-L25-DF-I-15

Light source color 2500K  
Brightness 334 cd  
Luminous flux 1025 lm  
Color rendering index Ra 94

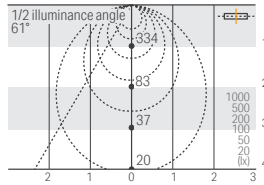
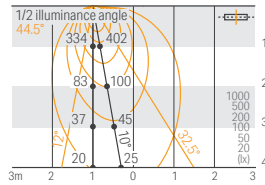

LCELY-1010-L22-DF-I-15

Light source color 2200K  
Brightness 311 cd  
Luminous flux 956 lm  
Color rendering index Ra 93

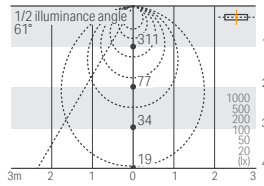
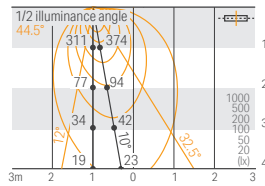

LCELY-1010-L20-DF-I-15

Light source color 2000K  
Brightness 284 cd  
Luminous flux 873 lm  
Color rendering index Ra 91

